

HUMES

Metallic Surface Boxes

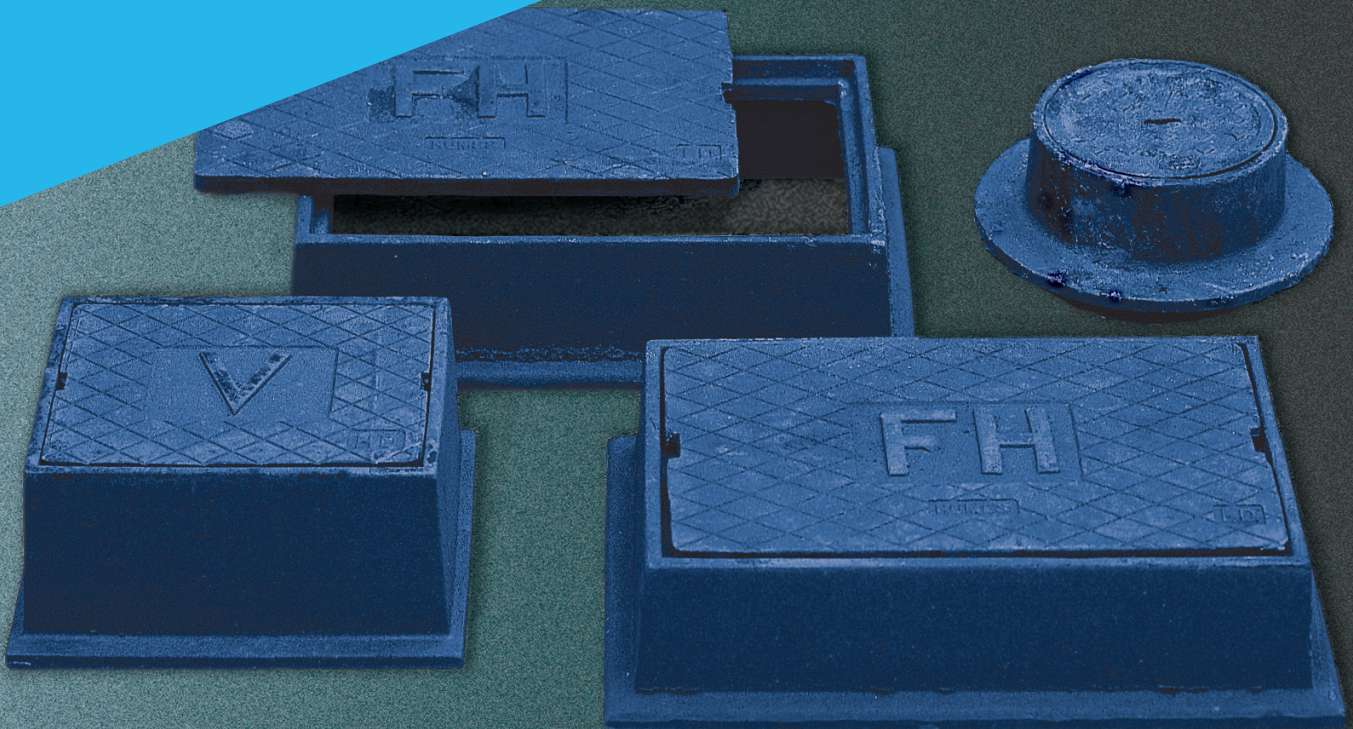

Humes Pipeline Systems provide a wide range of streetware

Benefits

Protecting and covering below ground services

Features

- High Strength construction
- Coated with black bituminous paint
- Flush mounting
- Material T220 Grey Iron

Product Branding

Surface boxes are available with various lid branding options. Individual local body names or logos can also be incorporated within the lid if required.

- Sluice Valve (SV)
- Service Valve (V)
- Peat Valve (PV)
- Toby Box (WW)
- Fire Hydrant (FH)
- Air Valve (AV)
- Water Meter (WM) or (METER)
- Gas (GAS)

Metallic Surface Boxes

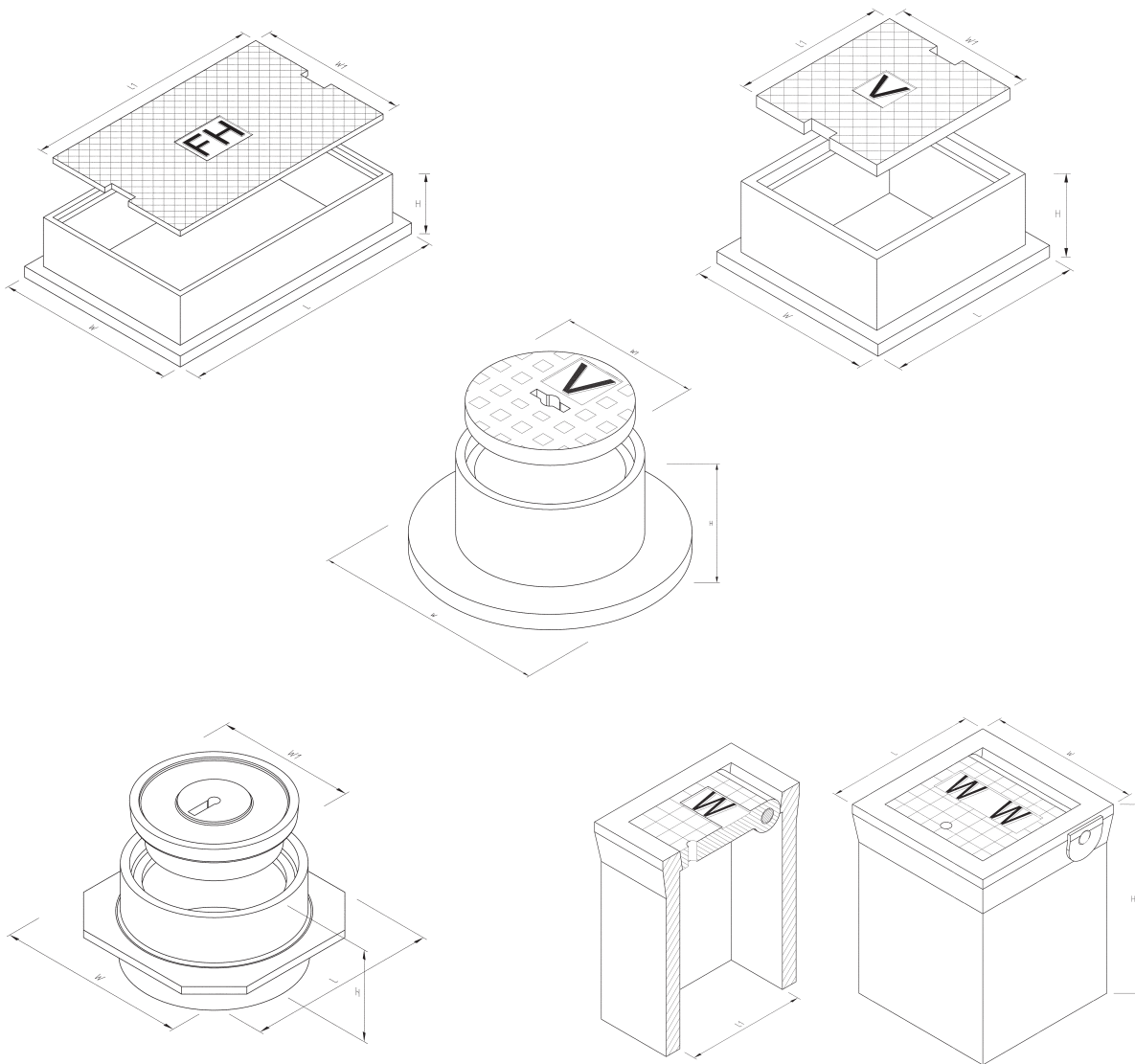

Dimensions

Box Type	Rating	Frame (mm)			Lid (mm)		Weight of Unit (kg)
		W	L	H	W1	L1	
Fire Hydrant	Heavy Duty	335	485	116	255	400	35kg
Fire Hydrant Box	Light Duty	335	445	150	245	400	28kg
Valve Box	Heavy Duty	310	336	150	225	250	23kg
Valve Box	Light Duty	300	225	145	180	230	18kg
150 Round Valve	Light Duty	270 dia		120	170 dia		12kg
Box 100 Valve Box	Light Duty	155	155	80	100		7kg
100 Square Toby Box	Light Duty	160	160	200	120	120	10kg

For further technical details or advice freephone 0800 502 112 or visit humes.co.nz

Buyers and users of the products described in this brochure must make their own assessment of the suitability and appropriateness of the products for their particular use and the conditions in which they will be used. All queries regarding product suitability, purpose or installation should be directed to the nearest Humes Sales Centre for service and assistance. Fletcher Concrete and Infrastructure Limited 2016. Created 03/16.

