



Streetware



A total solution
in streetware



Humes Certified Streetware





Humes products are manufactured to meet the stringent requirement of AS3996 – Access Covers and Frames.

As well as being manufactured to this standard, we also certify the products using third party accreditation through SAI Global. With many local bodies now adopting this standard, you can count on Hume’s products to deliver outstanding performance in all your applications.



AS3996 classifies products into different areas using a load classification system.

This system is as follows:-

Class	Typical Use	Nominal Wheel Loading (Kg)	Ultimate Load (kN)
 A10 <ul style="list-style-type: none"> • Pedestrians • Cyclists 	Areas (including footways) accessible only to pedestrians and pedal cyclists and closed to other traffic	330	10
 B80 <ul style="list-style-type: none"> • Passenger vehicles • Light vehicles 	Areas (including footways and light tractor paths) accessible to vehicles (excluding commercial vehicles) or livestock	2670	80
 C150 <ul style="list-style-type: none"> • Heavy commercial vehicles • Slow moving 	Malls and areas open to slow moving commercial vehicles	5000	150
 D210 <ul style="list-style-type: none"> • Heavy commercial vehicles 	Carriageways of roads and areas open to commercial vehicles	8000	210

The above information is given as a guide only. At all times, design considerations need to be assessed on individual installations.



Class B Manhole Set

Item #	78295
Class	B
Clear Opening (mm)	502
Frame Diameter (mm)	648
Lid Diameter (mm)	536
Frame Depth (mm)	66
Lid Depth (mm)	53
Weight (Kg)	60

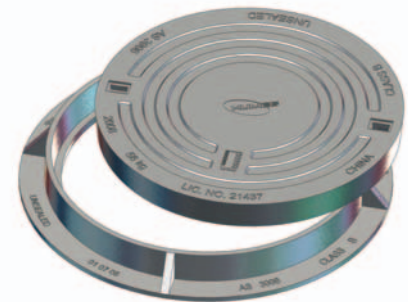

Class C Manhole Set

Item #	78294
Class	C
Clear Opening (mm)	482
Frame Diameter (mm)	682
Lid Diameter (mm)	534
Frame Depth (mm)	82
Lid Depth (mm)	71
Weight (Kg)	88

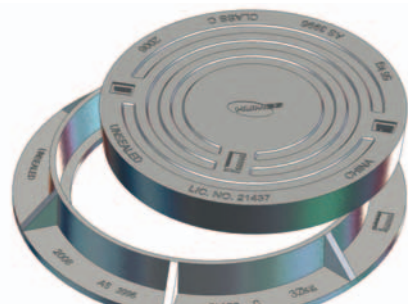

Class C Manhole Set – Spigoted Frame

Item #	78297
Class	C
Clear Opening (mm)	484
Frame Diameter (mm)	682
Lid Diameter (mm)	534
Frame Depth (mm)	117
Lid Depth (mm)	71
Weight (Kg)	94

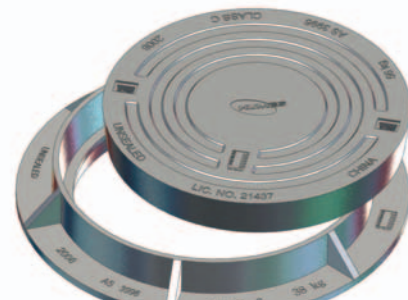

Class D Manhole Set – Non-Rock

Item #	78326
Class	D
Clear Opening (mm)	512
Frame Diameter (mm)	688
Lid Diameter (mm)	510
Frame Depth (mm)	92
Lid Depth (mm)	76
Weight (Kg)	101

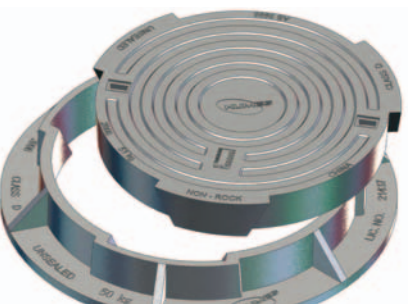

Class D Ductile Iron Manhole Cover set

Item #	78250
Class	D
Clear Opening (mm)	600
Frame Diameter (mm)	810
Lid Diameter (mm)	682
Frame Depth (mm)	102
Lid Depth (mm)	47
Weight (Kg)	80



Class D Ductile Iron Locking Manhole Set

Item #	78255
Class	D
Clear Opening (mm)	600
Frame Diameter (mm)	810
Lid Diameter (mm)	682
Frame Depth (mm)	102
Lid Depth (mm)	47
Weight (Kg)	80



Grate and Frame Sets

Description	Heavy Duty	Light Duty
Item #	74873	74860
Clear Opening (mm)	482	502
Frame Diameter (mm)	680	648
Lid Diameter (mm)	534	535
Frame Depth (mm)	82	67
Lid Depth (mm)	70	50
Weight (Kg)	78.7	50.6

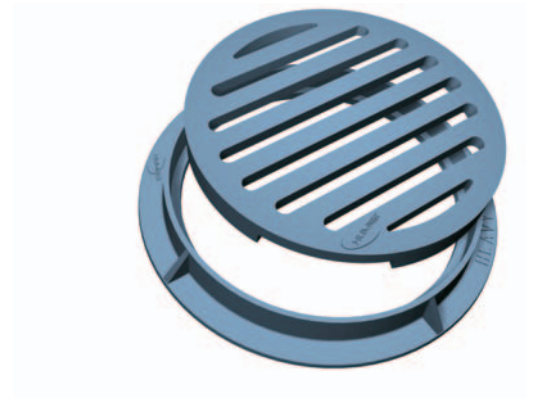

Manhole Safety Grill

For complete manhole safety, the new Humes Safety grill prevents falls and access to manholes. Available in either galvanised or stainless steel in either a 500mm or 610mm size with a locking option. Designed to be retrofitted to most manholes, the safety grill has been independently tested to a weight loading of 500KG.

Description	Item Code
Manhole Safety Grill 500 Galvanised	48502
Manhole Safety Grill 500 316 Stainless Steel	48503
Manhole Safety Grill 610 Galvanised	48504
Manhole Safety Grill 610 316 Stainless Steel	48505

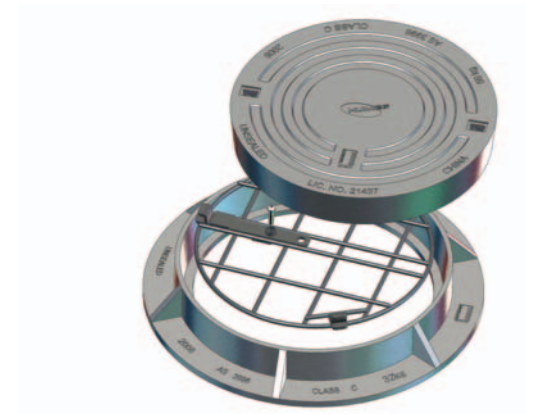

Frame and Grate Set

Item #	74843
Opening Nominal (mm)	675 x 450
Frame Dimensions (mm)	830 x 531
Grate Size (mm)	640 x 430
Frame Depth (mm)	120
Lid Depth (mm)	72
Weight (Kg)	129.6

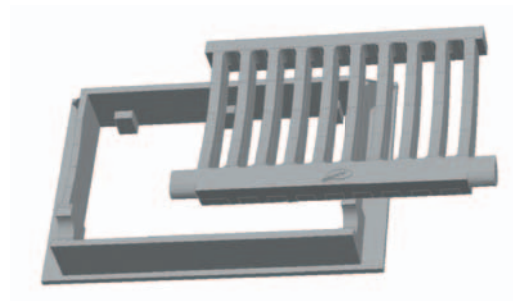

Frame and Grate set

Item #	74840
Opening Nominal (mm)	650 x 425
Frame Dimensions (mm)	800 x 530
Grate Size (mm)	640 x 403
Frame Depth (mm)	114
Lid Depth (mm)	86
Weight (Kg)	76.8



Frame and Grate Set

Item #	74824
Opening Nominal (mm)	450 x 450
Frame Dimensions (mm)	594 x 582
Grate Size (mm)	438 x 430
Frame Depth (mm)	102
Lid Depth (mm)	55
Weight (Kg)	69

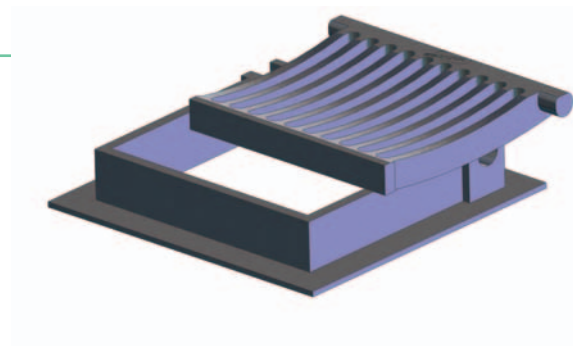

Class B Composite Access Cover

Item #	90800
Clear Opening (mm)	600 x 600
Frame Width (mm)	758
Cover Width (mm)	644
Frame Depth (mm)	758
Cover Depth (mm)	644
Weight (Set) (Kg)	24

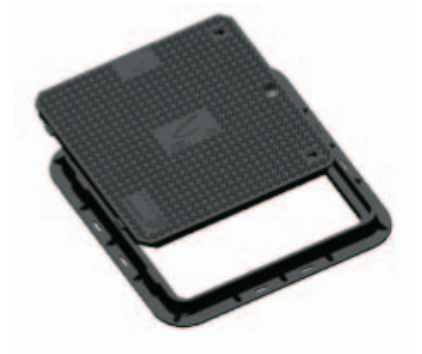

Class B Composite Access Cover

Item #	90818
Clear Opening (mm)	600 x 750
Frame Width (mm)	908
Cover Width (mm)	794
Frame Depth (mm)	758
Cover Depth (mm)	644
Weight (Set) (Kg)	31.5

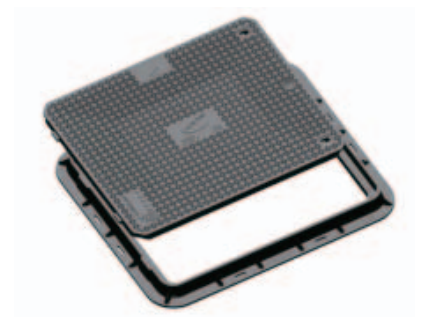

Class B Composite Access Cover

Item #	90803
Clear Opening (mm)	600 x 1200
Frame Width (mm)	1732
Cover Width (mm)	1244
Frame Depth (mm)	700
Cover Depth (mm)	644
Weight (Set) (Kg)	37.5

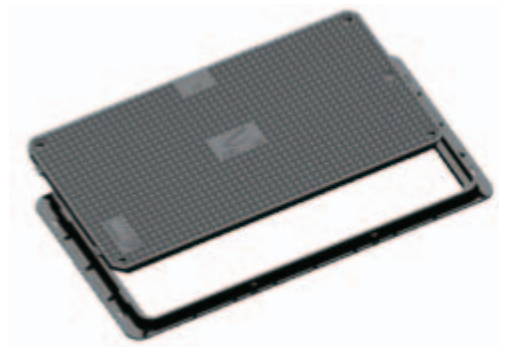

Class B Composite Access Cover

Item #	90813
Clear Opening (mm)	1200 x 1200
Frame Width (mm)	1402
Cover Width (mm)	1288
Frame Depth (mm)	1358
Cover Depth (mm)	1244
Weight (Set) (Kg)	87

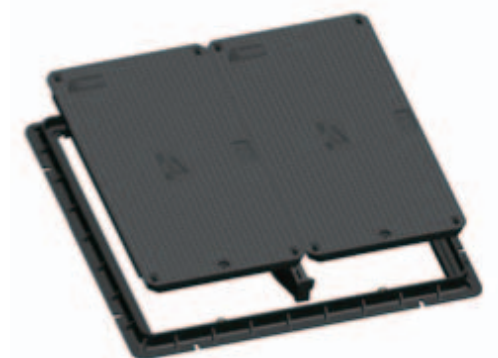

*Also requires item 90814 crossbar to complete set

For further technical details or advice freephone
0800 502 112 or visit www.humes.co.nz

Buyers and users of the products described in this brochure must make their own assessment of the suitability and appropriateness of the products for their particular use and the conditions in which they will be used. All queries regarding product suitability, purpose or installation should be directed to the nearest Humes Sales Centre for service and assistance. © Fletcher Concrete and Infrastructure Limited 2011. Printed 04/11.

