



Grease Trap



Humes Grease Traps are effective hydrodynamic settling systems designed to trap grease and suspended sediments generated by commercial food processing activities.

Baffles in the trap slow down the wastewater flow and reduce turbulence allowing the grease and water to cool and separate. The grease floats to the surface and is retained in the trap while the grease-free wastewater exits the grease trap into the sewer system.

Purpose

- Captures and separates grease waste

Benefits

- Reduces drain blockages
- Range of sizes and configurations to suit any application
- Light and heavy duty lid options
- Simple installation
- Easy to maintain
- Durable construction and high quality finish

Applications

- Cafes & Restaurants
- Hotels
- Hospitals
- Butcheries
- Supermarkets

The New Zealand Building Code states: 'In buildings other than residential housing, grease traps will be provided where wastewater is likely to contain grease'.

Grease Traps

With a wide range of sizes in rectangular and circular configurations, Humes can provide a Grease Trap to meet the conditions and restrictions of most environments. Rectangular grease traps (see below) suit certain locations whilst circular or round grease interceptors offer greater flexibility of shape, depth and lid options (see Grease Interceptor brochure or the Humes website).

Rectangular Grease Traps are available in the following sizes:

Item code	Fluid Capacity	Weight	Chambers	Lid Type	Lid Code	Lid No.	Lid weight	Inlet Invert (Lin)	Outlet Invert (Oin)	Outlet Soffit (Os)	External Height
04600	117 litre	770kg	2	Chequer plate lids	75338	2	24kg each	462	362	150	710
04654	353 litre	1520kg	3	Concrete with cast iron non-rock lids	Included	2	Included	735	635	150	1110 (inc lid)
04601	425 litre	1500kg	3	Concrete with cast iron non-rock lids	08345	1	540kg	690	590	200	1110
				chequer plate lids	75339	3	35kg each				
04641	2150 litre	3453kg	3	Concrete with cast iron non-rock lids	04642	3	858kg	1250	1150	200	1785 (inc lid)

All dimensions in mm.

Note: Refer to "Building Code G13/AS2 3.4 Grease Traps BIA" for plumbing configurations. Larger Grease Traps available upon request.

Lids

Chequer plate lids are suitable for non traffic site installations. Concrete with cast iron non-rock lids are rated for 0.85 HN – Non highway traffic.

Installation

Humes Grease Traps are supplied complete with lids and internally fixed baffles, ready to be placed into the excavated ground and connected to the site drainage system. Trap units must be laid on level, compacted hardfill to avoid uneven settlement and ensure optimum performance. External inlet and outlet pipes are sold separately through all Humes Sales Centres.

Maintenance

The load of pollutants and frequency of use can vary greatly with each application. Grease traps should be inspected at least every few days and cleaned out well before the pollutants reach the inlet/outlet level at the base of the unit. Failing to maintain the units regularly will result in the unit not working efficiently and can lead to blocking and flooding of the drainage system. All pollutants from the unit must be disposed of in accordance with the relevant local authority regulations. Grease traps need to be accessible for inspection and maintenance at any time.

Manufacturing standards

Precast manufacture is to NZS 3109:1997 with surface finishes to NZS 3114:1987, F4 and U2 for formed and trowelled respectively. For further details please contact your local Humes Sales Representative.

117 litre Grease Trap

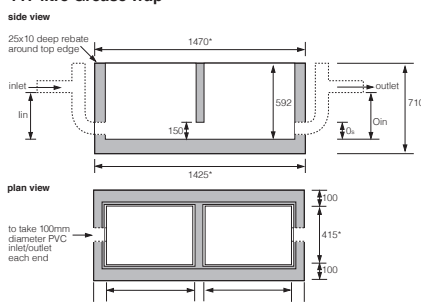

222 – 353 litre Grease Trap

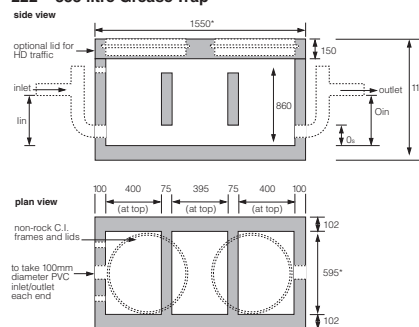

425 litre Grease Trap

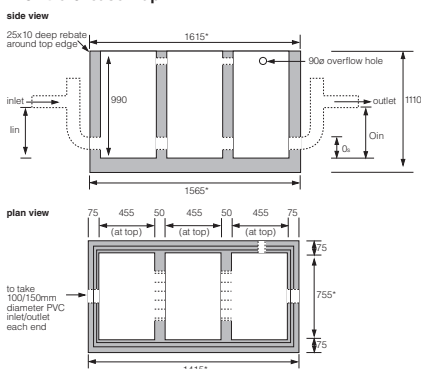

2150 litre Grease Trap

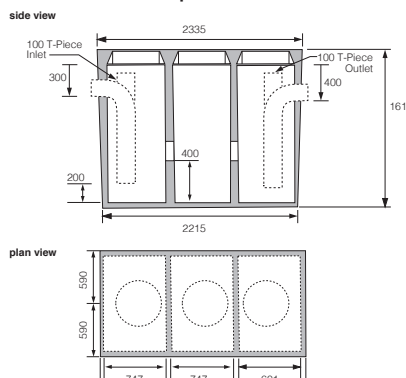

For further information or advice freephone
0800 502 112 or visit www.humes.co.nz

Buyers and users of the products described in this brochure must make their own assessment of the suitability and appropriateness of the products for their particular use and the conditions in which they will be used. Printed 09/13.

