



AVK FABRICATED FLANGE ADAPTOR, PN16

Non-tensile, dedicated to steel/PVC pipes

260/30



AVK fabricated flange adaptors is designed to add a flange to plain ended pipes, where a flange is required to connect to other pipeline accessories such as valves and pumps. They can be supplied to any pipeline diameter within their size range and are available for any ferrous and most rigid wall pipelines.



Product Description:

- Fabricated flange adaptor for water, wastewater and neutral liquids to max. 70° C

Standards:

- Standard flange drilling to EN1092-2 (ISO 7005-2), PN16



Features:

- Manufactured from mild steel
- EPDM vulcanized seals
- Can be supplied to any pipeline diameter within the size range
- Suitable for Cast Iron, Ductile Iron, Steel and PVC pipes
- Can be fitted with flanges of any standard on request
- Sealing range nominal diameter +2 mm to -5 mm
- Epoxy coated according to DIN 30677-2 and AVK guidelines



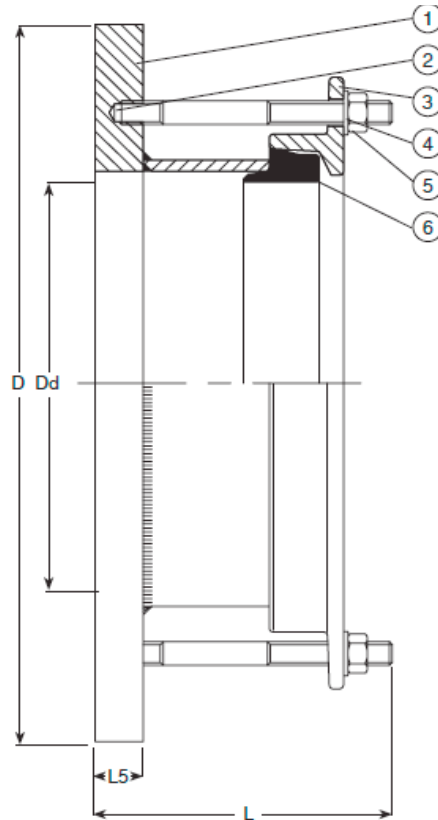

Component list

1. Body	Mild Steel to BS EN 10025 FE430 B	4. Washer	Zinc plated and passivated
2. Bolt	Steel 8.8, zinc plated and passivated	5. Nut	Steel 8.8, zinc plated and passivated
3. Gland ring	Mild Steel to BS EN 10025 FE430 B	6. Seal	EPDM rubber to BS EN 2494

Components can be substituted with equivalent or higher class materials.

Reference nos. and dimensions

AVK ref. nos.	DN mm	D mm	Dd mm	L mm	L5 mm	Bolt no.	Bolt holes	Theoretic weight kg
260-30-0355-10	350	520	356	190	25	8	28	34
260-30-0406-10	400	580	406	190	25	8	31	40
260-30-0457-10	450	640	457	190	25	10	31	46
260-30-0508-10	500	715	508	190	25	10	34	56
260-30-0609-10	600	840	610	190	25	10	37	71
260-30-0711-10	700	910	711	190	25	12	37	72
260-30-0812-10	800	1025	813	190	25	12	40	85
260-30-0914-10	900	1125	914	190	25	14	40	94
260-30-1016-10	1000	1255	1016	210	30	14	43	114
260-30-1220-10	1200	1485	1220	210	30	16	49	145

AVK FABRICATED FLANGE ADAPTOR, PN16
Non-tensile, dedicated to steel/PVC pipes

260/30

AVK ref. nos.	DN mm	Flange drilling	L mm	H mm	H3 mm	H1 to center bore mm	F mm	F1 mm	F2 mm	Theoretic weight kg
06-400-70-00337	400	PN10	310	960	1241	-	32	37	55	240
06-400-70-01337 (1)	400	PN16	310	960	1241	-	32	37	55	240
06-450-70-00337 (2)	450	PN10	330	1167	1487	1087	30	-	75	487
06-450-70-01337 (2)	450	PN16	330	1167	1487	1087	30	-	75	487
06-500-70-00337 (2)	500	PN10	350	1142	1500	1062	30	-	75	559
06-500-70-01337 (2)	500	PN16	350	1142	1500	1062	30	-	75	559
06-600-70-00337 (3)	600	PN10	390	1285	1705	1205	30	-	75	762
06-600-70-01337 (3)	600	PN16	390	1285	1705	1205	30	-	75	762

(1) Approved acc. to NF

(2) With F14 top flange. Body with blue epoxy coating RAL 5017.

(3) With F14 top flange. Not CE approved.