

PLAN (NO LID)

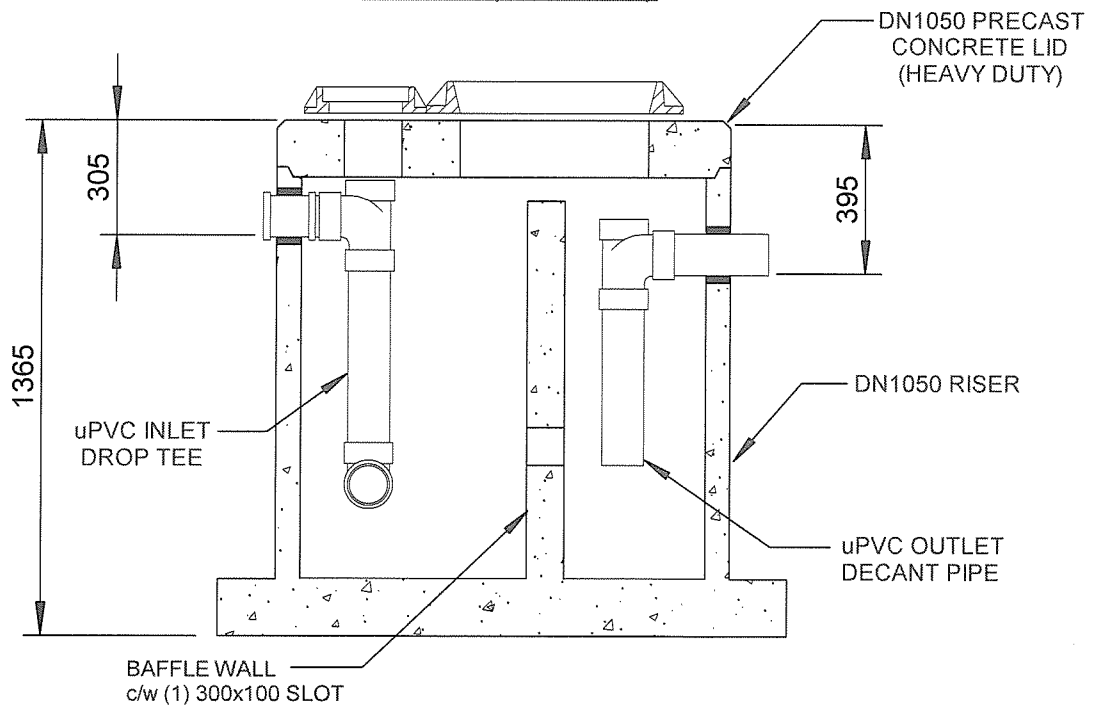

SECTION A-A

NOTES:

1. SWIFTLIFT LIFTING ANCHORS PROVIDED ON ALL COMPONENTS
2. TOTAL MASS: 2.12 TONNES
BODY: 1.57 TONNES
CONC LID: 0.55 TONNES (INCL. CAST IRON COVERS & FRAMES)
3. LID DESIGN - HEAVY DUTY, 0.85HN VEHICLE LOADS
4. CAPACITY - 639 LITRES, DEFINED AS TANK VOLUME BELOW INVERT LEVEL OF OUTLET PIPE
5. GREASE STORAGE VOLUME - 443 LITRES, S.G. = 0.9



Humes Pipeline Systems
Private Bag 92817
Auckland
Freephone 0800 502 112
www.humes.co.nz

**GREASE INTERCEPTOR
MODEL GT0500
GENERAL ASSEMBLY
(HEAVY DUTY)**

Drawn By:	Date:
C THORPE	07-11-08
Checked by:	Scale:
	1 : 20
Reference:	
Drawing No.:	Issue:
HUMES 3002	0