

**PLAN (NO LID)**

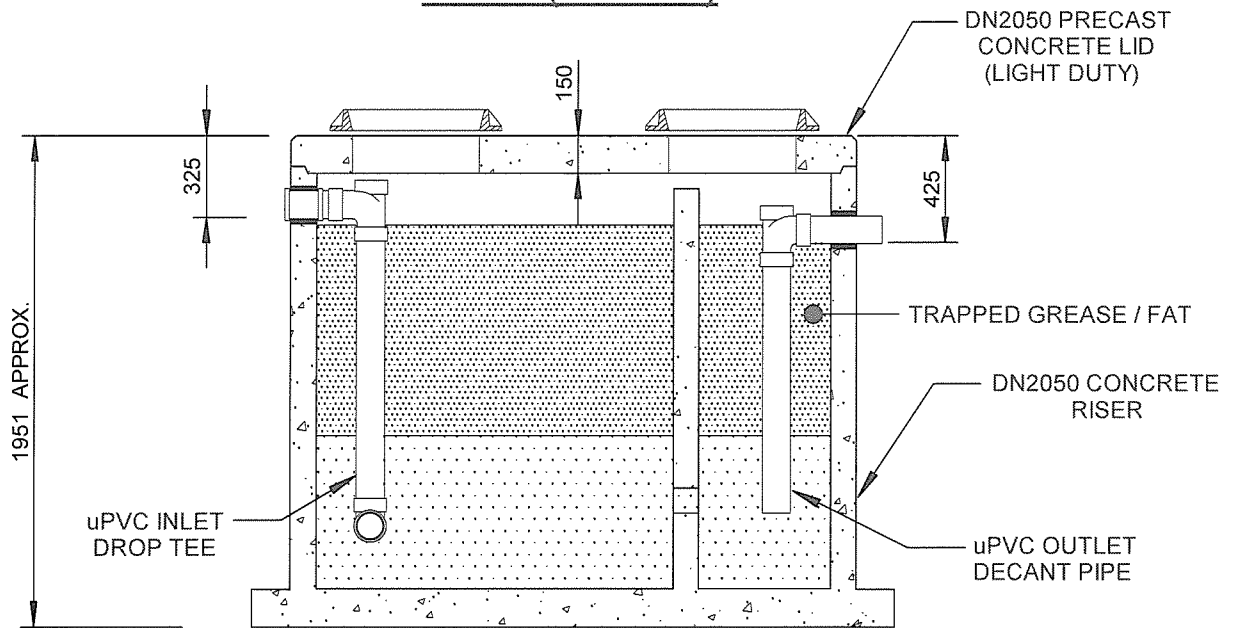

**SECTION A-A**

**NOTES:**

1. SWIFTLIFT LIFTING ANCHORS PROVIDED ON ALL COMPONENTS
2. TOTAL MASS: 7.01 TONNES  
 BODY: 5.57 TONNES  
 CONC LID: 1.44 TONNES (INCL. CAST IRON COVERS & FRAMES)
3. LID DESIGN - LIGHT DUTY, DO NOT SUBJECT TO VEHICLE LOADS
4. CAPACITY - 4,130 LITRES, DEFINED AS TANK VOLUME BELOW INVERT LEVEL OF OUTLET PIPE
5. GREASE STORAGE VOLUME - 3,570 LITRES, S.G. = 0.9



Humes Pipeline Systems  
 Private Bag 92817  
 Auckland  
 Freephone 0800 502 112  
 www.humes.co.nz

**GREASE INTERCEPTOR  
 MODEL GT4000  
 (LIGHT DUTY)**

**GENERAL ASSEMBLY DETAILS**

Drawn By:	C THORPE	Date:	27-02-09
Checked By:		Scale:	1 : 30
Reference:			
Drawing No.:	HUMES 3047	Issue:	0