



# AVK STEM CAPS FOR GATE VALVES

57/16



To AS 2638.1 and AS 2638.2



**Use:**

- For gate valves, non rising stem, inside screw type

**Note:**

- Cannot be used for:
  - OS&Y gate valves
  - Series 57/42 and 57/43 ISO mounting pad valves



Anti-Clockwise  
Close



Clockwise  
Close



Recycled Water  
Use



ACC



CC



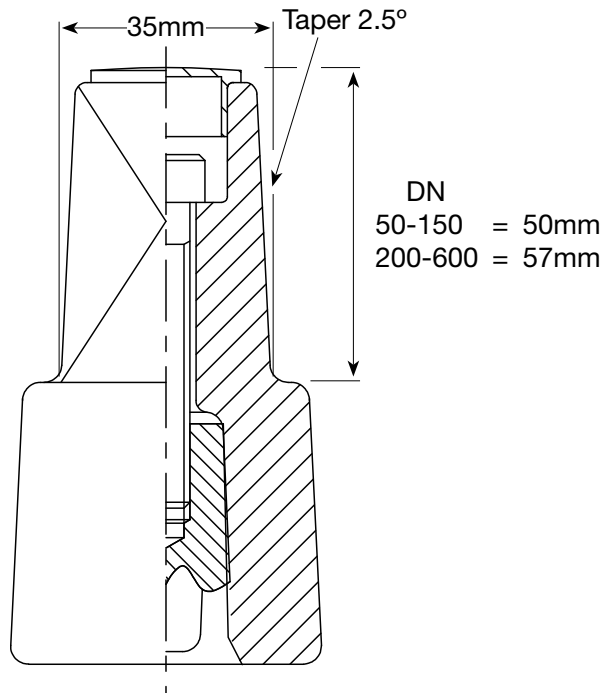

**Component list**

- |             |  |
|-------------|--|
| 1. Stem cap | Ductile Iron, 400-12 to AS 1831                      |
| 2. Coating  | Electrostatically applied epoxy resin to AS/NZS 4158 |
| 3. Screw    | 316 Stainless Steel                                  |
| 4. Insert   | Plastic (Red = CC, White = ACC)                      |

Components can be substituted with equivalent or higher class materials.

**Reference nos. and dimensions**

AVK ref. nos.		To suit series					Theoretical weight kg
CC	ACC	Purple	57/40 - PN16	57/90 - PN16	57/80 - PN25	55 - PN16	
57-050-1605	57-050-1612	-	-	-	-	-	0.89
57-090-1605	57-090-1612	57-090-1614	-	50-100	-	-	0.89
57-100-1605	57-100-1612	57-100-1614	50-100	-	50-100	-	0.89
57-150-1605	57-150-1612	57-150-1614	150	150-200	150	-	1.06
57-300-1605	57-300-1612	-	200-300	225-300	200-300	-	1.31
57-400-1605	57-400-1612	-	375-400	-	-	-	1.84
57-600-1605	57-600-1612	-	-	-	-	450-600	1.49