



AVK BUTTERFLY VALVE PN16

813/82

Concentric butterfly valve, double flanged, loose liner, PN16 to AS 4795.2
Face to face dimensions: AS 4795.2 PN16 (ISO 5752 series 13)
Drilled to AS 4087 Fig. B5 / AS 2129 Table D

Use:

- For water and neutral liquid applications
 - Valve designed for use up to 70°C
 - Where applicable; for AS 4020 compliance, max temp = 40°C
- Note: Always observe pipe material recommended operating temperatures

Tests:

- Hydraulic test to AS 4795.2
 - Seat: 17.6 bar (1.1 x AOP)
 - Body: 24 bar (1.5 x AOP)

Actuation:

- Lever: DN80 to DN150
- Gearbox: DN150 to DN500
- Bare stem: DN80 to DN500



Australian Standard
AS4795.2:2011
Lic. SMK20435
SAI Global

Expect... **AVK**

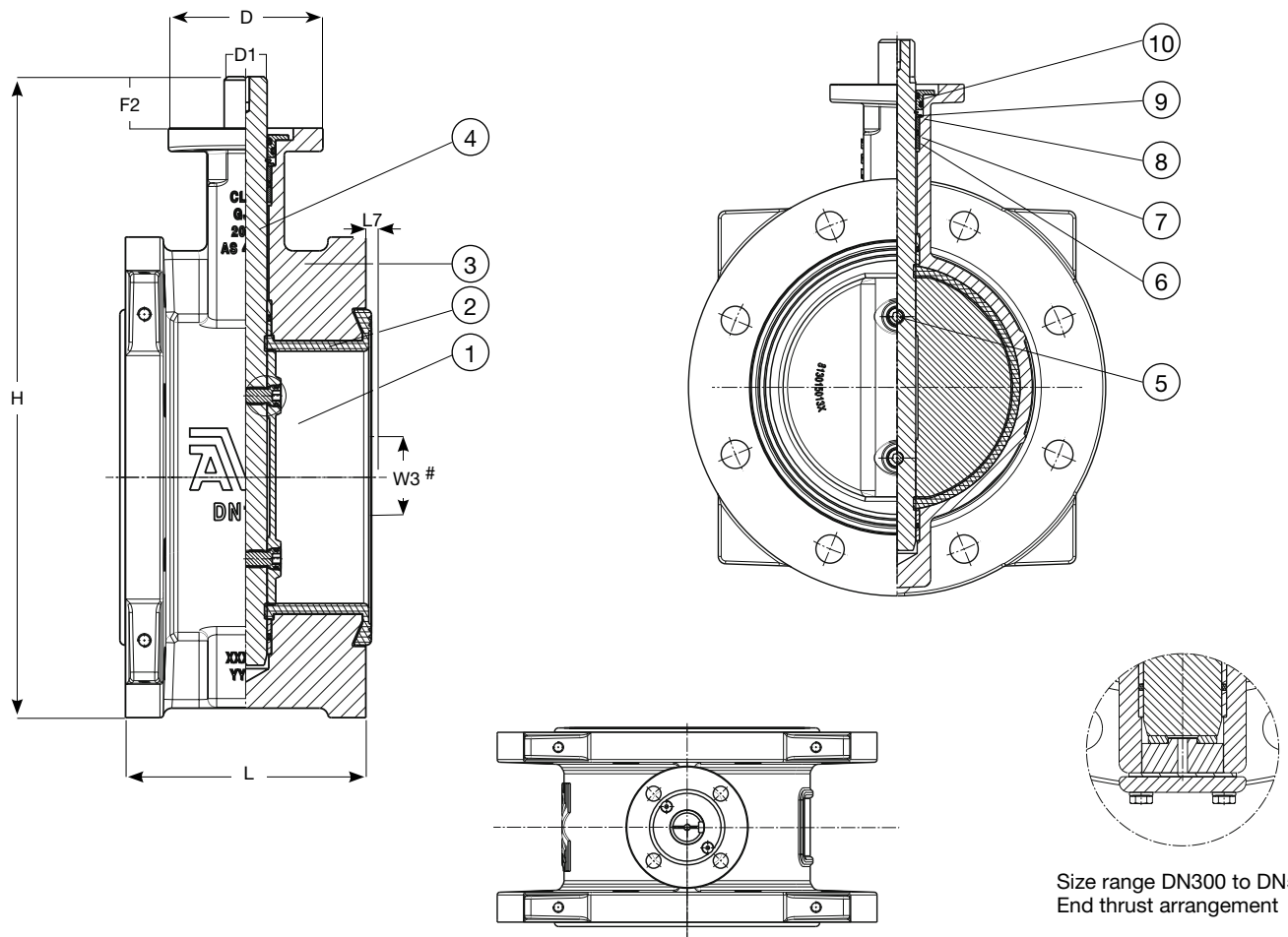

Size range DN300 to DN500
End thrust arrangement

Component list

Valve:		8. Bushing	Aluminium Bronze to AS 1565
1. Disc	Stainless Steel 316	9. Circlip	Stainless Steel
2. Liner	EPDM/ESW.80	10. Stem sealing	Bronze BS 1400 LG2 to AS 1565
3. Body	Ductile Iron 400-15/500-7	Operator:	
4. Stem	Stainless Steel 316	Lever	Stainless Steel
5. Pin bolt	Stainless Steel 316	Gearbox	Rotork ABW series
6. Bushing	Aluminium Bronze to AS 1565		
7. O-ring	NBR		

Components can be substituted with equivalent or higher class materials.

Reference nos. and dimensions

AVK ref. nos.	DN mm	L	H	F2	D1	Top flange ISO 5211	D	W3#	L7 kilos	Weight kilos	Operator kilos
813-0080-82451201	80	114	286	34	15	F07	90	-	-	10.55	2.2*
813-0100-82451201	100	127	323	34	15	F07	90	-	-	13.0	2.2*
813-0150-82451201	150	140	375	34	25	F07	90	51	8	22.1	2.2*
813-0150-82451202	150	140	375	34	25	F07	90	51	8	22.1	3.5**
813-0200-82451202	200	152	447	44	25	F10	125	129	26	35.0	3.5**
813-0250-82451202	250	165	519	44	35	F10	125	188	45	48.9	8.5**
813-0300-82451202	300	178	604	54	35	F12	175	242	63	74.3	8.5**
813-0350-82451202	350	190	695	64	45	F14	210	298	84	98	14.0**
813-0400-82451202	400	216	769	79	60	F16	210	338	95	133.6	18.8**
813-0450-82451202	450	222	822	79	60	F16	210	395	118	168.0	32.2**
813-0500-82451202	500	229	911	79	60	F16	210	447	138	205.5	32.2**

* Standard with lever
** Standard with gear box
NB: Bare shaft optional