

**Flange adaptor with tensile resistant sealing ring for PE- pipe**  
**For Polyethylene pipes PE 100, PN 16 - SDR11 to AS/NZ 4130**  
**Flanges to AS4087 Fig B5; AS 2129 Tables D and E**

**Use:**

For water, sewage and neutral liquids.  
 Total angular deflection of  $\pm 3.5$  degrees.  
 For use in cold water applications.

**Test:**

Highest allowable test pressure  
 1.5 x PN for the pipe used at 20°C.



AVK always recommend the Series 05 support bush be utilised when using Polyethylene pipe systems and AVK tensile resistant sealing ring (Supa Plus™) fittings and valves.

**Materials:**

Flange/ Gland ring	Ductile iron, AS 1831 Gr. 400-12 min.
Coating	Fusion bonded epoxy to AS 4158
Tensile sealing ring	Gun metal, DIN 17005 RG5 / EPDM rubber
Nut	Stainless steel (AISI 316), A4 grade 70 PTFE coated
Rectangular bolt and washer	Stainless steel, A2 grade 70
Cap	Plastic

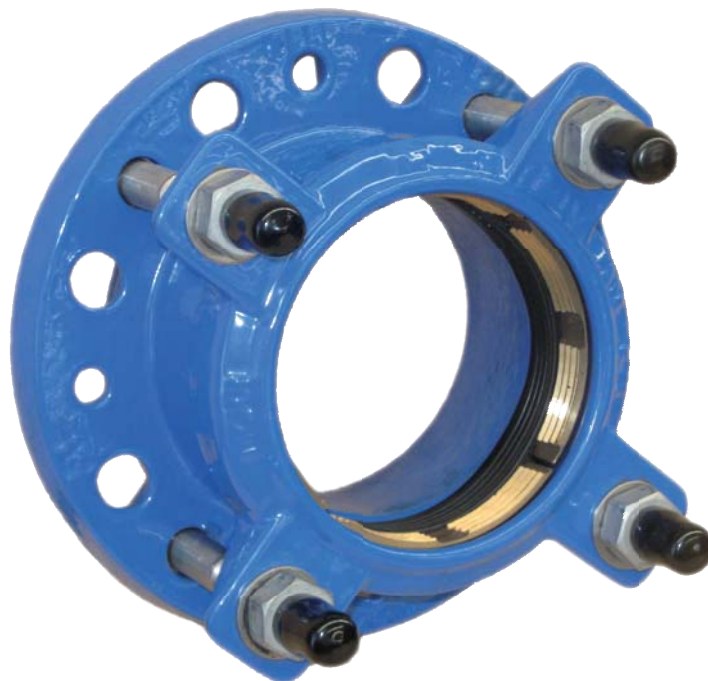

AVK Australia's website contains the latest product information and data sheets.

Designs, materials and specifications shown are subject to change without notice due to our continuing program of product development.



Flange adaptor with tensile resistant sealing ring for PE- pipe  
 For Polyethylene pipes PE 100, PN 16 - SDR11 to AS/NZ 4130  
 Flanges to AS4087 Fig B5; AS 2129 Tables D and E

### Component list

- |                         |                     |
|-------------------------|---------------------|
| 1. Tensile sealing ring | 5. Washer           |
| 2. Adaptor flange       | 6. Rectangular bolt |
| 3. Bracket              | 7. Cap              |
| 4. Hex. nut             | 8. Support bush     |

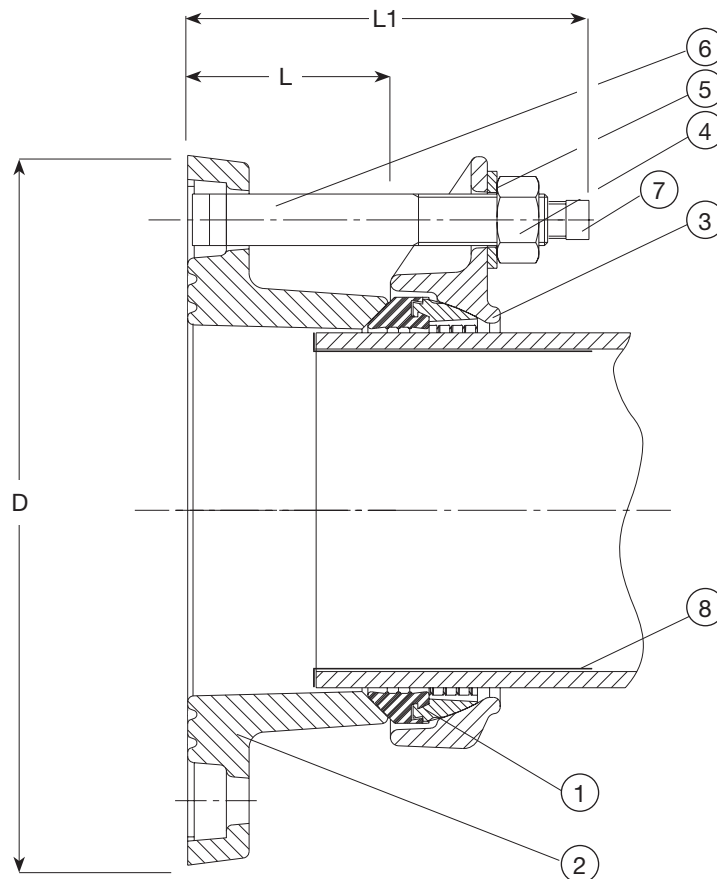

Ref. nos. PN 10/16	DN Flange	OD PE	Bolts	L mm	Theoretic Weight kilos	Flange Drilling **	D mm	L1 mm
623-10-090-054212	80	90	2 M16	62	4.7	4 & 5	175	125
623-10-110-054312	100	110	4 M16	63	6.6	4 & 5	215	125
623-10-125-024312	100	125	4 M16	63	6.8	2	240	125
623-10-125-054312	125	125	4 M16	63	6.8	4 & 5	250	125
623-10-140-054312	125	140	4 M16	63	6.9	4 & 5	250	125
623-10-160-054212	150	160	4 M16	63	8.3	4 & 5	280	125
623-10-180-054212	150	180	4 M16	63	10.0	4 & 5	280	160
623-10-200-054312	200	200	8 M16	64	14.1	4 & 5	340	125
623-10-225-054312	200	225	8 M16	64	15.1	4 & 5	405	160
623-10-250-054212	250	250	6 M16	88	24.5	4	405	175
623-10-250-064212	250	250	6 M16	88	24.5	5	405	175
623-10-280-054212	250	280	6 M16	88	25.0	4	405	175
623-10-280-064212	250	280	6 M16	88	25.0	5	405	175
623-10-315-054312	300	315	6 M16	88	28.6	4 & 5	460	175

\*\* Flange drilling: 2 = AS 4087 Fig. B5, AS 2129 Table D, AS 2129 Table E - for combination DN100 flange 125mm PE pipe  
 4 = AS 4087 Fig. B5, AS 2129 Table D  
 5 = AS 2129 Table E

SUPPORT BUSH	
PE 100, PN 16 - SDR 11	
Ref. nos.	
05-090-54000	
05-110-74000	
05-125-74000	
05-125-74000	
05-140-74000	
05-160-74000	
05-180-74000	
05-200-74000	
05-225-74000	
05-250-74000	
05-250-74000	
05-280-74000	
05-280-74000	
05-315-74000	