



AVK SUPA PLUS™ END CAP

624/10



End cap with tensile resistant sealing ring for PE-pipe
For Polyethylene pipes PE100, PN16 - SDR11 to AS/NZ 4130



Use:

- For water, sewage and neutral liquids
- Total angular deflection of ± 3.5 degrees
- For use in cold water applications

Approvals:

- EPDM to WRAS

Options:

- Drilled and tapped 2" BSP takeoff point

- AVK always recommend the series 05 support bush be utilised when using Polyethylene pipe systems and AVK tensile resistant sealing ring (Supa Plus™) fittings and valves.



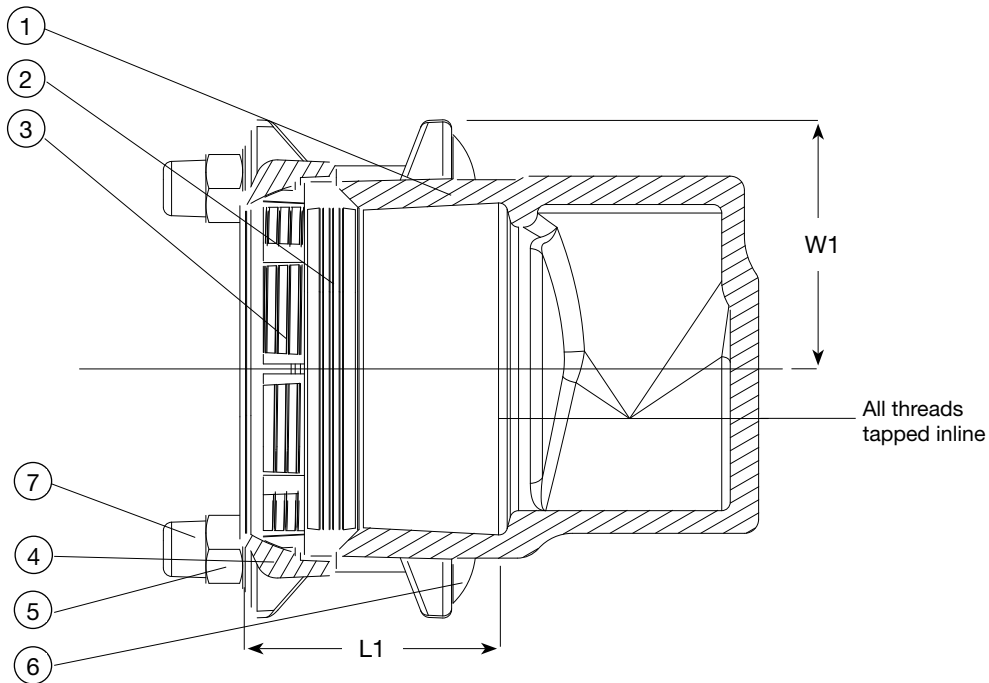

Component list

| | |
|-----------------|---------------------------------------|
| 1. Body | Ductile Iron, AS 1831 Gr. 400-12 min. |
| 2. Gasket | Ductile Iron, AS 1831 Gr. 400-12 min. |
| 3. Tensile ring | Gun metal, DIN 17005 RG5/EPDM rubber |
| 4. Bracket | Ductile Iron, AS 1831 Gr. 400-12 min. |
| 5. Nut | Stainless Steel, A4, PTFE coated |
| 6. Bolt | Stainless Steel A2 |
| 7. Cap | Plastic |

Components can be substituted with equivalent or higher class materials.

Reference nos. and dimensions

| AVK ref. nos. | DN mm | Inline thread BSP | OD mm | Bolts | L1 mm | W1 mm | Weight kh | SUPPORT BUSH PE 100, PN 16 - SDR 11 Ref. no.s |
|------------------------|-------|-------------------|-------|-------|-------|-------|-----------|---|
| 624-10-090-61-00-06-1 | 80 | 2" | 90 | 2M16 | 95 | 100 | 6 | 05-090-54001 |
| 624-10-110-61-00-06-1 | 100 | 2" | 110 | 4M16 | 95 | 110 | 8 | 05-110-74001 |
| 624-10-125-61-00-06-1 | 125 | 2" | 125 | 4M16 | 95 | 120 | 9 | 05-125-74001 |
| 624-10-140-61-00-06-01 | 125 | 2" | 140 | 4M16 | 95 | 127 | 10 | 05-140-74001 |
| 624-10-160-61-00-06-1 | 150 | 2" | 160 | 4M16 | 100 | 138 | 11 | 05-160-74001 |
| 624-10-180-61-00-06-1 | 150 | 2" | 180 | 4M16 | 110 | 143 | 13 | 05-200-74001 |
| 624-10-200-61-00-06-1 | 200 | 2" | 200 | 6M16 | 140 | 159 | 16 | 05-200-74001 |
| 624-10-225-61-00-06-1 | 200 | 2" | 225 | 6M16 | 140 | 171 | 20 | 05-225-74001 |
| 624-10-250-61-00-06-1 | 250 | 2" | 250 | 6M16 | 145 | 187 | 24 | 05-250-74001 |
| 624-10-280-61-00-06-1 | 250 | 2" | 280 | 6M16 | 145 | 195 | 26 | 05-280-74001 |
| 624-10-315-61-00-06-1 | 300 | 2" | 315 | 6M16 | 145 | 220 | 3 | 05-315-74001 |