



AVK FABRICATED STRAIGHT COUPLING, PN16

258/30



The Series 258 is a fabricated coupling for all ferrous, GRP* and PVC pipes, suitable for use with water and neutral liquids (sewage) up to 16 Bar.



Product Description:

- PN16 dedicated pipe coupling

Test/Approvals:

- Hydraulic test according to 1.5 x PN
- Materials approved according to WRAS



Features:

- Manufactured to suit nominal pipe OD, with a sealing range of: nominal diameter +2mm to - 5mm
- Sheraplex coated fasteners
- Corrosion resistant construction
- Fusion bonded epoxy coating
- Short lead times
- EPDM seals
- Maximum Working Pressure: 25 Bar
- Temperature Range: -10°C to +70°C Insulation essential for temperatures of 0°C and below

Options:

- Can be manufactured to suit a specific pipe OD between DN269-600mm
- Sizes up to DN1200mm available upon request
- Alternative fasteners available: Zinc Plated - passivated and Stainless Steel A2/A4

Note:

- *Suitable only for cc-GRP (Centrifugally cast-glass reinforced polyester)
- This fitting is not designed for end load resistant applications



Expect... **AVK**

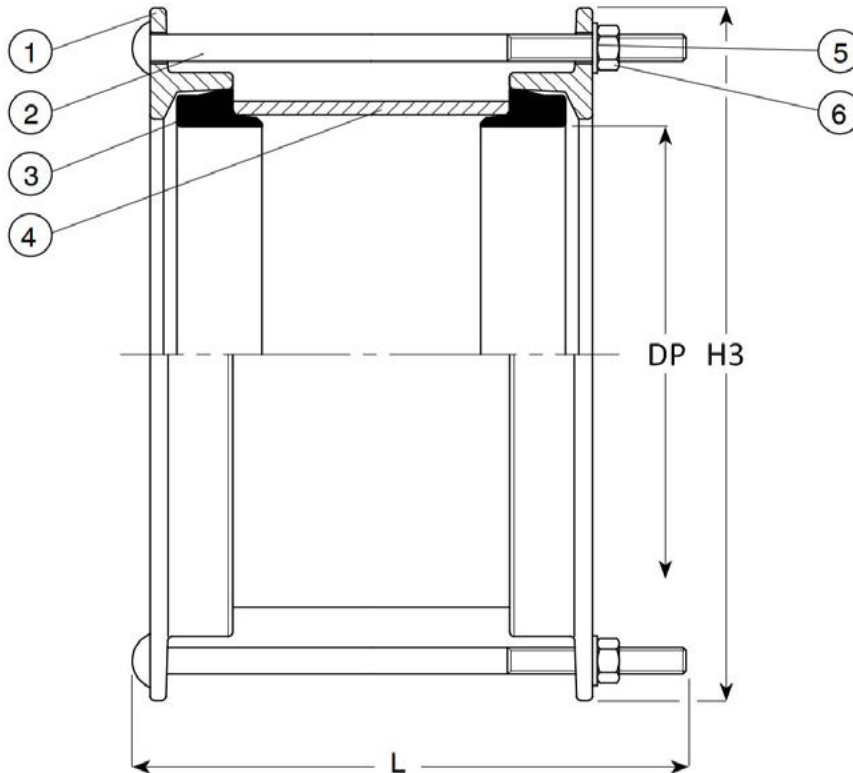

Component list

1. Gland Ring	Mild Steel, grade FE 430 B to BS EN 10025	10025	5. Washers	Zinc plated and passivated
2. Bolts	Cup square grade 8.8, Sheraplex coated		6. Nuts	Hexagon, grade 8, Sheraplex coated
3. Seals	EPDM to BS EN 681-1		7. Coating	Fusion bonded epoxy coating to WIS 4-52-01
4. Body	Mild Steel, grade FE 430 B to BS EN			

Components can be substituted with equivalent or higher class materials.

Reference nos. and dimensions

AVK ref. nos.	DP Nom. O.D. mm	H3 mm	L mm	Bolt no.	Theoretic weight kg
258-30-0320-26	320	427	270	16	25
258-30-0327-26	327	434	270	16	26
258-30-0428-26	428	535	270	16	38
258-30-0460-26	460	567	270	20	40
258-30-0511-26	511	618	270	20	48
258-30-0532-26	532	639	270	20	51
258-30-0613-26	613	720	270	20	58
258-30-0635-26	635	742	270	20	60

AVK ref. nos.	DN mm	Flange drilling	L mm	H mm	H3 mm	H1 to center bore mm	F mm	F1 mm	F2 mm	Theoretic weight kg
06-400-70-00337	400	PN10	310	960	1241	-	32	37	55	240
06-400-70-01337 (1)	400	PN16	310	960	1241	-	32	37	55	240
06-450-70-00337 (2)	450	PN10	330	1167	1487	1087	30	-	75	487
06-450-70-01337 (2)	450	PN16	330	1167	1487	1087	30	-	75	487
06-500-70-00337 (2)	500	PN10	350	1142	1500	1062	30	-	75	559
06-500-70-01337 (2)	500	PN16	350	1142	1500	1062	30	-	75	559
06-600-70-00337 (3)	600	PN10	390	1285	1705	1205	30	-	75	762
06-600-70-01337 (3)	600	PN16	390	1285	1705	1205	30	-	75	762

(1) Approved acc. to NF

(2) With F14 top flange. Body with blue epoxy coating RAL 5017.

(3) With F14 top flange. Not CE approved.