



SERIES 57/46 & 57/86 RESILIENT SEATED GATE VALVES INSTALLATION, OPERATION & MAINTENANCE MANUAL



Instruction for use

Thank you for selecting an AVK product. With correct use, it will give long and reliable service. This manual has been prepared to assist you install, operate and maintain the valve to the maximum efficiency. For ease of reference, it has been divided into sections covering all aspects of use, and it is in the users best interests to read it and ensure that it is fully understood.



Health and Safety

It is always recommended that wherever work is being carried out on a valve that the valve is fully depressurised prior to carrying it out, and for the convenience draining of the line may be beneficial.

It is essential that the user of the valve is aware of the weight of the components and/or assemblies that must be handled and manipulated during installation and maintenance. It is the users responsibility to ensure that safe working practices are followed at all times.

Whenever AVK products are installed, operated, or maintained, it is essential that the staff that undertake these operations be adequately trained. The hazards of pressurised liquids and gases can be severe, and it is the responsibility of the users to ensure that trained, competent staff undertake these duties. This manual has been designed to assist, but it can never fully replace quality training in the workplace. AVK technical staff will always be available to answer any questions relating to specific problems that may not be covered by this manual.

AVK products are designed and manufactured to be fit for purpose, and to a high and reliable standard. This provides a safe product with minimum risk to health when used correctly for the purpose for which it was designed. However, this assumes that the equipment is used and maintained in accordance with the manual, and the user is advised to study this manual, and to make it available to all staff that may need to refer to it.

AVK cannot be held responsible for any incidents arising from incorrect installation, operation or maintenance. The responsibility for this must rest wholly with the user.

SERIES 57/46 & 57/86 RESILIENT SEATED GATE VALVES INSTALLATION, OPERATION & MAINTENANCE MANUAL

1. Introduction

AVK series 57/46 gate valves are available in DN50 to DN300. The valve has a full and straight bore corresponding to the nominal diameter and can be installed independent of the flow direction. To keep the advantage of the full and straight bore vertical installation is recommended, however, flow/pressure limitations outlined below should be observed.

The valves are 100% factory tested hydrostatically.

IT IS IMPORTANT TO STATE OPERATING TEMPERATURE, PRESSURE, MEDIUM AND OPERATING CONDITIONS WITH ENQUIRIES/ORDERS, SO THE MOST SUITABLE VALVE WILL BE SUPPLIED FOR YOUR SPECIFIC PURPOSE.

Materials:

Castings (gland flange, body, bonnet & stem cap)
Ductile Iron, 500-7 to AS 1831

Coating
Fusion bonded epoxy (FBE)

Stem, gland flange bolts
Stainless Steel

Wedge
Ductile Iron, with EPDM rubber

Bonnet bolts
DN50-250
PN16 Grade 8.8, PN25 Grade 12.9, sealed with hot melt
DN300-400
PN16 and PN25 Grade 12.9, sealed with hot melt

Refer to individual datasheets for specific information

PN16



SERIES 57/46 & 57/86 RESILIENT SEATED GATE VALVES INSTALLATION, OPERATION & MAINTENANCE MANUAL

Component list

- | | | | |
|---------------|-------------------|--------------------|---------------|
| 1. Valve body | 7. Bonnet bolt | 13. O-ring | 19. Stud bolt |
| 2. Wedge body | 8. Bonnet gasket | 14. Washer | 20. Washer |
| 3. Wedge | 9. Valve bonnet | 15. Gland | 21. Handwheel |
| 4. Wedge nut | 10. Hot melt | 16. Hexagon nut | 22. Stem nut |
| 5. Pin | 11. Gland bushing | 17. Gland follower | |
| 6. Stem | 12. O-ring | 18. Yoke | |

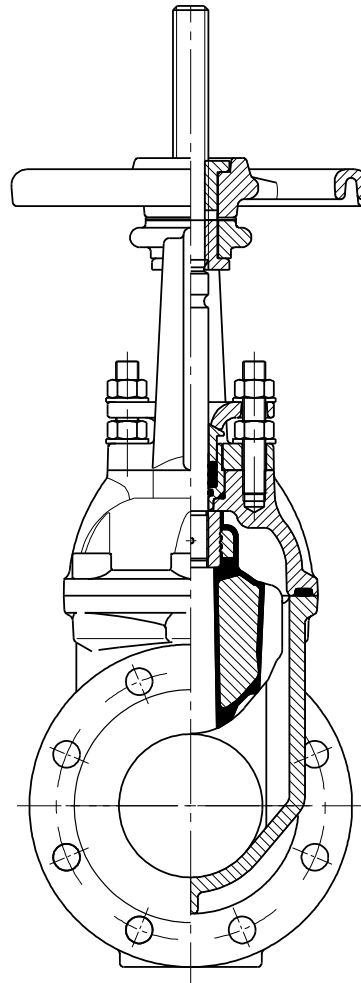
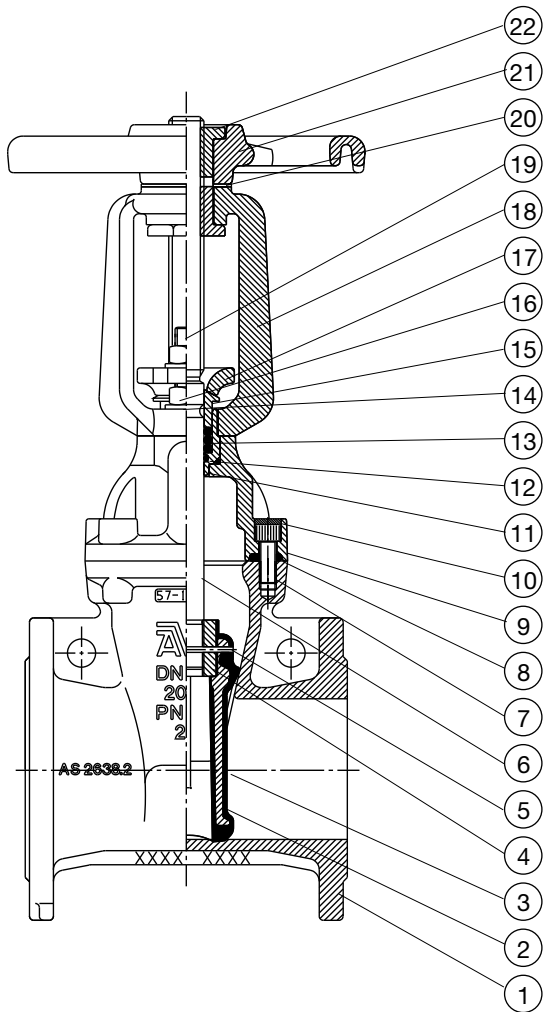

SERIES 57/46 & 57/86 RESILIENT SEATED GATE VALVES INSTALLATION, OPERATION & MAINTENANCE MANUAL

2. Installation

- When installing the gate valves, ensure that the seats and the flange faces are clean.
- When valves are provided with lifting lugs, plates or eye nuts, these must be used to lift the valve.
- To ensure adequate sealing it is important to select the correct type of gasket for the medium concerned, gaskets with the correct flange size must be used.
- Place valve between pipe flanges, and insert the bolts.
- Tighten bolts loosely.
- Tighten bolts in a diagonal sequence to ensure flanges are pulled parallel.
- Finally tighten bolts to correct torque levels as recommended in WSA 109.

2.1. Bolts

2.1.1 Bolt size

The following table shows bolt size you should use for which valve dimensions.

DN	Table B5		AS 2129 Table E		AS 2129 Table F	
	Bolts	Quantity	Bolts	Quantity	Bolts	Quantity
50	M16	4	M16	4	M16	4
80	M16	4	M16	4	M16	8
100	M16	4	M16	8	M16	8
150	M16	8	M20	8	M20	12
200	M16	8	M20	8	M20	12
225	M16	8	-	-	-	-
250	M16	8	M20	12	M24	12
300	M20	12	M24	12	M24	16
375	M24	12	M24	12	M27	16
400	M24	12	M24	12	M27	20

2.2. Gland Follower

Prior to pressurisation check gland follower nuts are finger tight. After pressurisation operate valve and check for weeping. Nip nuts (16) until weeping stops.

Note: If nuts are excessively tightened torque operation of the valve is increased dramatically.

3. Operation

Series 57/46 valves are suitable for use with clean water or neutral liquids up to 70°C. Minimum liquid temperature must be above freezing. Insulation is essential for external temperatures on 0°C to - 10°C. The valves are operated manually by handwheel.

SERIES 57/46 & 57/86 RESILIENT SEATED GATE VALVES INSTALLATION, OPERATION & MAINTENANCE MANUAL

4. Maintenance

4.1 Replacement of Handwheel

Component list

1. Valve body	6. Stem	11. Gland bushing	16. Hexagon nut	21. Handwheel
2. Wedge body	7. Bonnet bolt	12. O-ring	17. Gland follower	22. Stem nut
3. Wedge	8. Bonnet gasket	13. O-ring	18. Yoke	
4. Wedge nut	9. Valve bonnet	14. Washer	19. Stud bolt	
5. Pin	10. Hot melt	15. Gland	20. Washer	

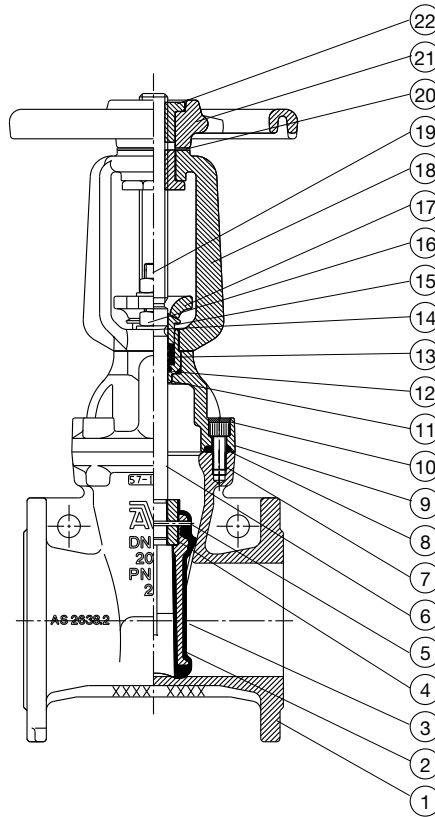

- Remove nuts (16) from studs (19).
 - Lift gland follower (17) up and remove nuts (16) and washers (14). Then turn handwheel (21) clockwise until upper stem nut (22) comes off assembly.
 - Place top half of stem nut (22) into new handwheel (21) and align with hexagon. The stem nut should fit neatly inside the recess in the top of the handwheel.
Place the stem nut and handwheel assembly on top of yoke/anti friction washer assembly and align top half of stem nut with the bottom half via the lugs.
- Note: The stem nuts will only go together one way as the lugs are different widths.**
- Thread handwheel (21) onto stem anti clockwise making sure that the yoke (18) bolt holes line up with the bonnet studs (19) with no interference.
 - Thread handwheel (21) onto stem until the yoke (18) sits flush on top of the bonnet (9) with the wedge (3) raised from the seat position.
 - Lift gland follower (17) up and place washer (14) and nut (16) onto studs (19) to secure yoke (18) to bonnet (9).
 - Tighten nuts (16) that secure yoke (18) to bonnet (9), lower gland follower over studs (19) and place one washer (14) on top of each stud (19).
 - Place a small amount of Loctite 680 Threadlocker onto the nuts that secure the gland follower (17).
 - Place nuts onto studs and tighten evenly to fingertight.
 - After pressurisation operate valve and check for weeping. Nip nuts (16) until weeping stops.

Important: Ensure that valve operates smoothly and freely when opening and closing.

SERIES 57/46 & 57/86 RESILIENT SEATED GATE VALVES INSTALLATION, OPERATION & MAINTENANCE MANUAL

4.2 Replacement of Stem O-Rings (13)

Component list

1. Valve body	6. Stem	11. Gland bushing	16. Hexagon nut	21. Handwheel
2. Wedge body	7. Bonnet bolt	12. O-ring	17. Gland follower	22. Stem nut
3. Wedge	8. Bonnet gasket	13. O-ring	18. Yoke	
4. Wedge nut	9. Valve bonnet	14. Washer	19. Stud bolt	
5. Pin	10. Hot melt	15. Gland	20. Washer	

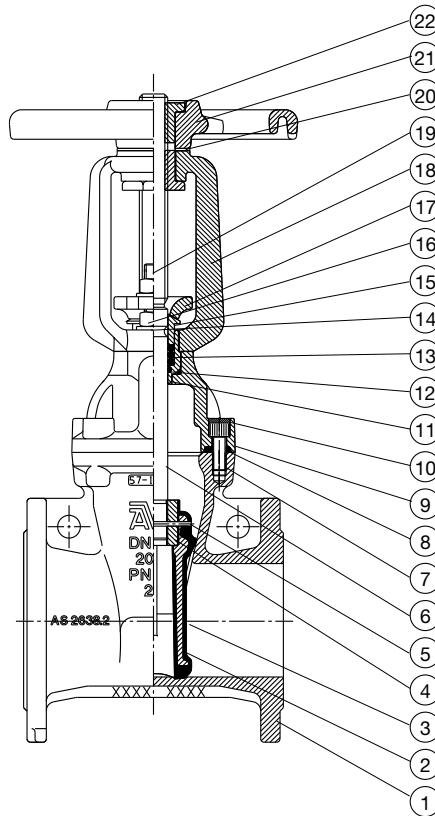

WARNING: To perform the following steps, be sure the water main supply line has been shut off, and that the pressure has been bled off! Also provide sufficient clearing around the valve so that no soil or debris may fall into it.

- Remove the two upper gland follower / yoke nuts (16) and washers (14). Lift the gland follower (17) up off of the stud bolts (19).
- Lift the gland (15) to access the three stem seal O-rings (13). **NOTE:** These O-rings are split-type O-rings. When replacing them, ensure that the splits **DO NOT** align. Rotate the splits at approximately 90 degree intervals.
- Reverse steps a) and b) for re-assembly.

Repressurise the system. At this time, if there is a leak around the gland be sure that the upper gland follower / yoke nuts are screwed down evenly on the stud bolts. Tighten the nuts ¼ turn each until the leak stops.