

PLAN (NO LID)

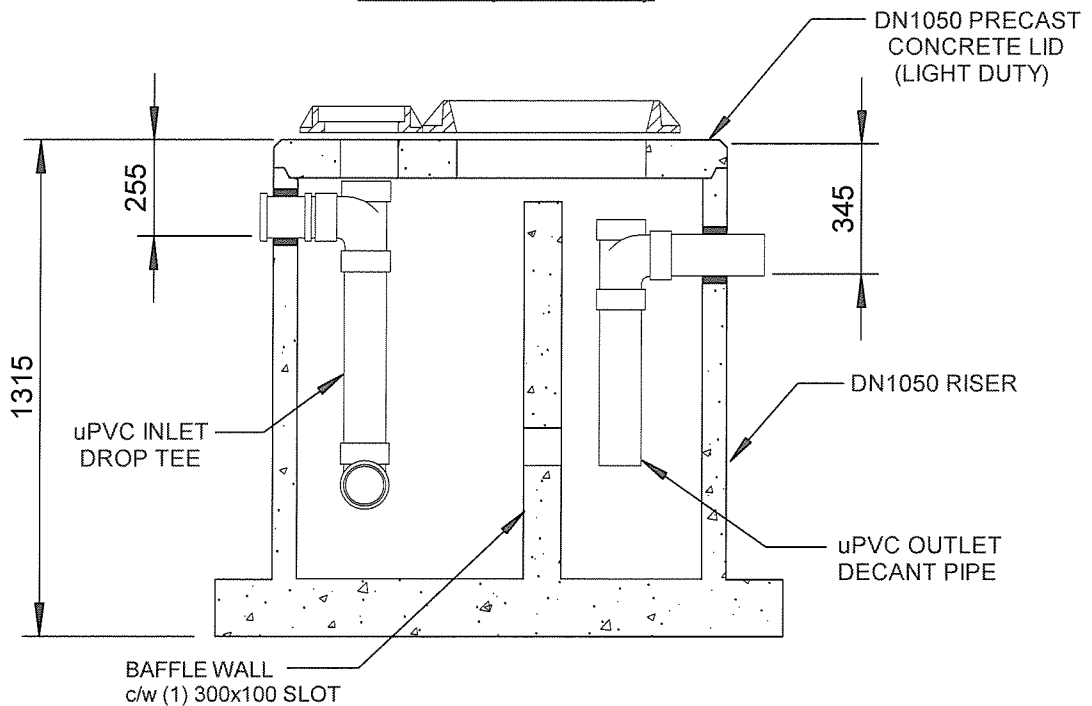

SECTION A-A

NOTES:

1. SWIFTLIFT LIFTING ANCHORS PROVIDED ON ALL COMPONENTS
2. TOTAL MASS: 1.99 TONNES
 BODY: 1.57 TONNES
 CONC LID: 0.42 TONNES (INCL. CAST IRON COVERS & FRAMES)
3. LID DESIGN - LIGHT DUTY, NO VEHICLE LOADS
4. CAPACITY - 639 LITRES, DEFINED AS TANK VOLUME BELOW INVERT LEVEL OF OUTLET PIPE
5. GREASE STORAGE VOLUME - 443 LITRES, S.G. = 0.9



Humes Pipeline Systems
 Private Bag 92817
 Auckland
 Freephone 0800 502 112
 www.humes.co.nz

**GREASE INTERCEPTOR
 MODEL GT0500
 GENERAL ASSEMBLY
 (LIGHT DUTY)**

Drawn By:	C THORPE	Date:	13-04-07
Checked By:		Scale:	1 : 20
Reference:			
Drawing No.:	HUMES 3000	Issue:	3