



## AVK SINGLE BAND REPAIR CLAMP C/W SOCKET, TYPE FSA-10

729/C1

AVK repair clamps ensure a cost effective and reliable solution for quick repairs on steel, copper, asbestos cement, Cast Iron and plastic pipes. A pipe with a hole, crack or full fracture will be repaired permanently. The Stainless Steel repair clamps are passivated in order to ensure an optimum corrosion resistance. The repair clamps are provided with a waffle structured rubber gasket and rounded tops to create a fully circumferential seal.

**Use:** For water, sewage and neutral liquids to max. 70°C  
**Hydraulic tests:** Body 1.2 x PN (type test only)  
**Applicable standards:** Design to Manufacturer Standard and AS 4181  
Indication pressure class for (waste)water: 16 bar for DN40 up to DN150, 10 bar for DN175 up to DN300 and 6 bar for DN350

**Options:** Any length and width could be made to order  
Socket outlet from DN20 to DN100 BSP/NPT Thread  
Ribs/bolt welded with an interval 50mm

**Materials:**

<b>Body</b>	Stainless Steel Grade 316
<b>Clamp</b>	Stainless Steel Grade 316
<b>Bridge</b>	Stainless Steel Grade 316
<b>Ribs</b>	Stainless Steel Grade 316
<b>Socket</b>	Stainless Steel Grade 316
<b>Rubber lining</b>	NBR
<b>Bolts</b>	Stainless Steel 316 c/w PTFE coating
<b>Nut</b>	Stainless Steel Grade 316
<b>Washer</b>	Stainless Steel Grade 316
<b>Bolt/ ribs interval</b>	100mm



Expect... **AVK**

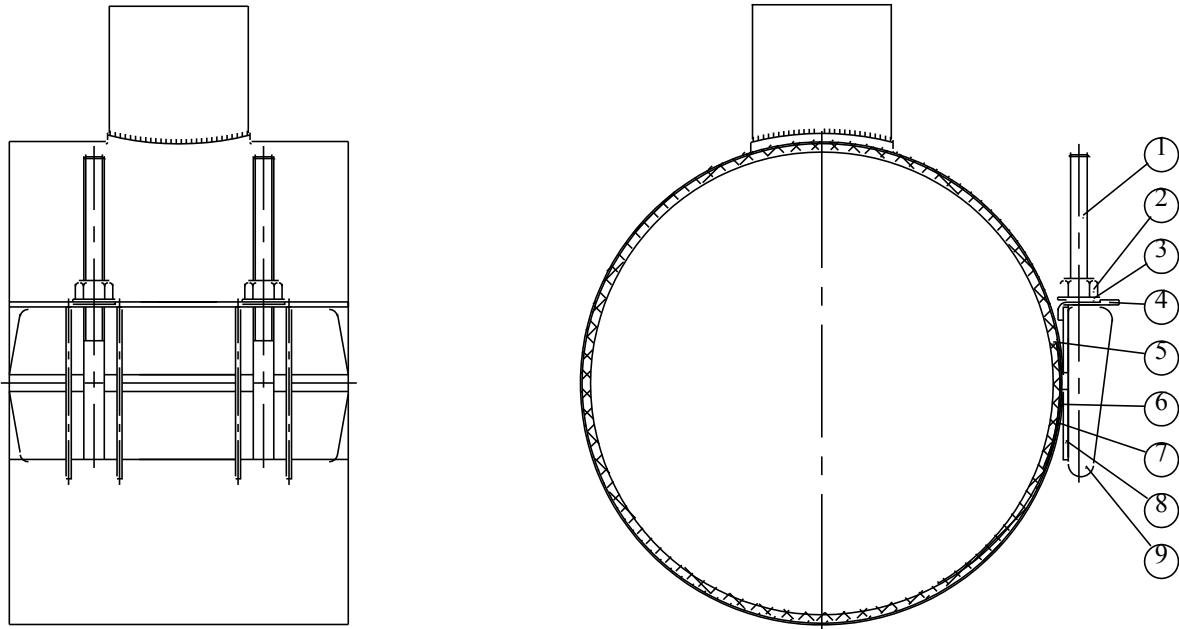

**Component list**

1. Stud 316 Stainless Steel	Teflon coated	6. Body plate	316 Stainless Steel
2. Nut	316 Stainless Steel	7. Spanner plate	316 Stainless Steel
3. Washer	316 Stainless Steel	8. Side plate	316 Stainless Steel
4. Bridge	316 Stainless Steel	9. Ribs	316 Stainless Steel
5. Rubber sealing	Nitrile (NBR)		

Components can be substituted with equivalent or higher class materials.

Reference nos. and dimensions

AVK ref. nos	Outer Dia.	
	Lower	Range (mm) Upper
729A10052DDEE06GG2J	48	52
729A10058DDEE06GG2J	54	58
729A10067DDEE06GG2J	60	67
729A10074DDEE06GG2J	67	74
729A10077DDEE06GG2J	70	77
729A10080DDEE06GG2J	73	80
729A10083DDEE06GG2J	76	83
729A10089DDEE06GG2J	82	89
729A10094DDEE06GG2J	87	94
729A10098DDEE06GG2J	91	98
729A10102DDEE06GG2J	95	102
729A10108DDEE06GG2J	98	108
729A10112DDEE06GG2J	102	112
729A10116DDEE06GG2J	106	116
729A10118DDEE06GG2J	108	118
729A10123DDEE06GG2J	113	123
729A10128DDEE06GG2J	118	128
729A10131DDEE06GG2J	121	131
729A10135DDEE06GG2J	125	135
729A10142DDEE06GG2J	132	142
729A10145DDEE06GG2J	135	145
729A10155DDEE06GG2J	145	155
729A10161DDEE06GG2J	151	161
729A10170DDEE06GG2J	160	170
729A10175DDEE06GG2J	165	175
729A10177DDEE06GG2J	167	177
729A10180DDEE06GG2J	170	180
729A10184DDEE06GG2J	174	184
729A10186DDEE06GG2J	176	186
729A10190DDEE06GG2J	180	190
729A10196DDEE06GG2J	186	196
729A10203DDEE06GG2J	193	203
729A10210DDEE06GG2J	200	210
729A10220DDEE06GG2J	210	220
729A10225DDEE06GG2J	215	225
729A10229DDEE06GG2J	219	229
729A10233DDEE06GG2J	223	233
729A10239DDEE06GG2J	229	239
729A10240DDEE06GG2J	230	240
729A10247DDEE06GG2J	237	247
729A10249DDEE06GG2J	239	249
729A10254DDEE06GG2J	244	254
729A10260DDEE06GG2J	250	260
729A10263DDEE06GG2J	253	263
729A10271DDEE06GG2J	261	271
729A10276DDEE06GG2J	266	276
729A10280DDEE08GG2J	270	280
729A10283DDEE08GG2J	273	283
729A10291DDEE08GG2J	281	291
729A10300DDEE08GG2J	290	300
729A10310DDEE08GG2J	300	310
729A10320DDEE08GG2J	310	320
729A10325DDEE08GG2J	315	325
729A10330DDEE08GG2J	320	330
729A10335DDEE09802J	325	335
729A10344DDEE08GG2J	334	344
729A10345DDEE08GG2J	340	350
729A10360DDEE08GG2J	350	360

**DD- Width**

00	100mm
01	150mm
02	200mm
03	250mm
04	300mm
05	400mm
06	500mm
07	600mm
08	700mm
09	800mm
10	900mm

**EE - Body& Rib/ Rubber/ Stud Distance**

01	A2/ EPDM/ 50
02	A2/ EPDM/ 100
03	A2/ NBR/ 50
04	A2/ NBR/ 100
09	A4/ EPDM/ 50
10	A4/ EPDM/ 100
11	A4/ NBR/ 50
12	A4/ NBR/ 100

**GG - Branching**

1B	20mm BSP female thread
1C	25mm BSP female thread
1E	40mm BSP female thread
1G	50mm BSP female thread
1H	65mm BSP female thread
1K	80mm BSP female thread
1L	100 mm BSP female thread