



## SERIES 01/71 GATE VALVE WITH SUPA PLUS™ COUPLING FOR PE PIPE INSTALLATION, OPERATION & MAINTENANCE MANUAL

### Instruction for use

Thank you for selecting an AVK product. With correct use, it will give long and reliable service. This manual has been prepared to assist you install, operate and maintain the valve to the maximum efficiency. For ease of reference, it has been divided into sections covering all aspects of use, and it is in the users best interests to read it and ensure that it is fully understood.

### Health and Safety

It is always recommended that wherever work is being carried out on a valve that the valve is fully depressurised prior to carrying it out, and for the convenience draining of the line may be beneficial.

It is essential that the user of the valve is aware of the weight of the components and/or assemblies that must be handled and manipulated during installation and maintenance. It is the users responsibility to ensure that safe working practices are followed at all times.

Whenever AVK products are installed, operated, or maintained, it is essential that the staff that undertake these operations be adequately trained. The hazards of pressurised liquids and gases can be severe, and it is the responsibility of the users to ensure that trained, competent staff undertake these duties. This manual has been designed to assist, but it can never fully replace quality training in the workplace. AVK technical staff will always be available to answer any questions relating to specific problems that may not be covered by this manual.

AVK products are designed and manufactured to be fit for purpose, and to a high and reliable standard. This provides a safe product with minimum risk to health when used correctly for the purpose for which it was designed. However, this assumes that the equipment is used and maintained in accordance with the manual, and the user is advised to study this manual, and to make it available to all staff that may need to refer to it.

AVK cannot be held responsible for any incidents arising from incorrect installation, operation or maintenance. The responsibility for this must rest wholly with the user.

# SERIES 01/71 GATE VALVE WITH SUPA PLUS™ COUPLING FOR PE PIPE INSTALLATION, OPERATION & MAINTENANCE MANUAL

## 1. Introduction

AVK gate valves with SupaPlus coupling ends are available for PE-pipe systems 90mm to 315mm. The combination of a Resilient Seated Gate Valve with mechanical restraint reduces the amount of time and components required with traditional flange gate valves and adaptors.

The valves are 100% factory tested hydrostatically.

**IT IS IMPORTANT TO STATE OPERATING TEMPERATURE, PRESSURE, MEDIUM AND OPERATING CONDITIONS WITH ENQUIRIES/ORDERS, SO THE MOST SUITABLE VALVE WILL BE SUPPLIED FOR YOUR SPECIFIC PURPOSE.**

### Materials:

**Castings (gland flange, body, bonnet & stem cap)**  
Ductile Iron GGG-40 to DIN 1693, EN-GJS-400: EN 1563  
1998

**Coating**  
Fusion bonded epoxy (FBE)

**Stem, gland flange bolts, nut & washer**  
Stainless Steel

**Wedge**  
Ductile Iron, with EPDM rubber

**Bonnet bolts**  
Grade 8.8, sealed with hot melt

**Thrust collar and stem seal box**  
Dezincification resistant brass

Refer to individual datasheets for specific information



# SERIES 01/71 GATE VALVE WITH SUPA PLUS™ COUPLING FOR PE PIPE INSTALLATION, OPERATION & MAINTENANCE MANUAL

## Component list

- |                  |                     |                      |                 |
|------------------|---------------------|----------------------|-----------------|
| 1. Wedge-rubber  | 7. Bracket          | 13. Screw cover      | 19. Bushing     |
| 2. Wedge-casting | 8. Nut              | 14. Bonnet           | 20. O-ring      |
| 3. Body          | 9. Square neck bolt | 15. O-ring stem seal | 21. Wiper ring  |
| 4. Stem nut      | 10. Cap             | 16. Stem collar      | 22. Stem        |
| 5. Gasket        | 11. Bonnet bolt     | 17. Gland O-ring     | 23. Gland bolts |
| 6. Tensile ring  | 12. Bonnet gasket   | 18. Gland flange     |                 |

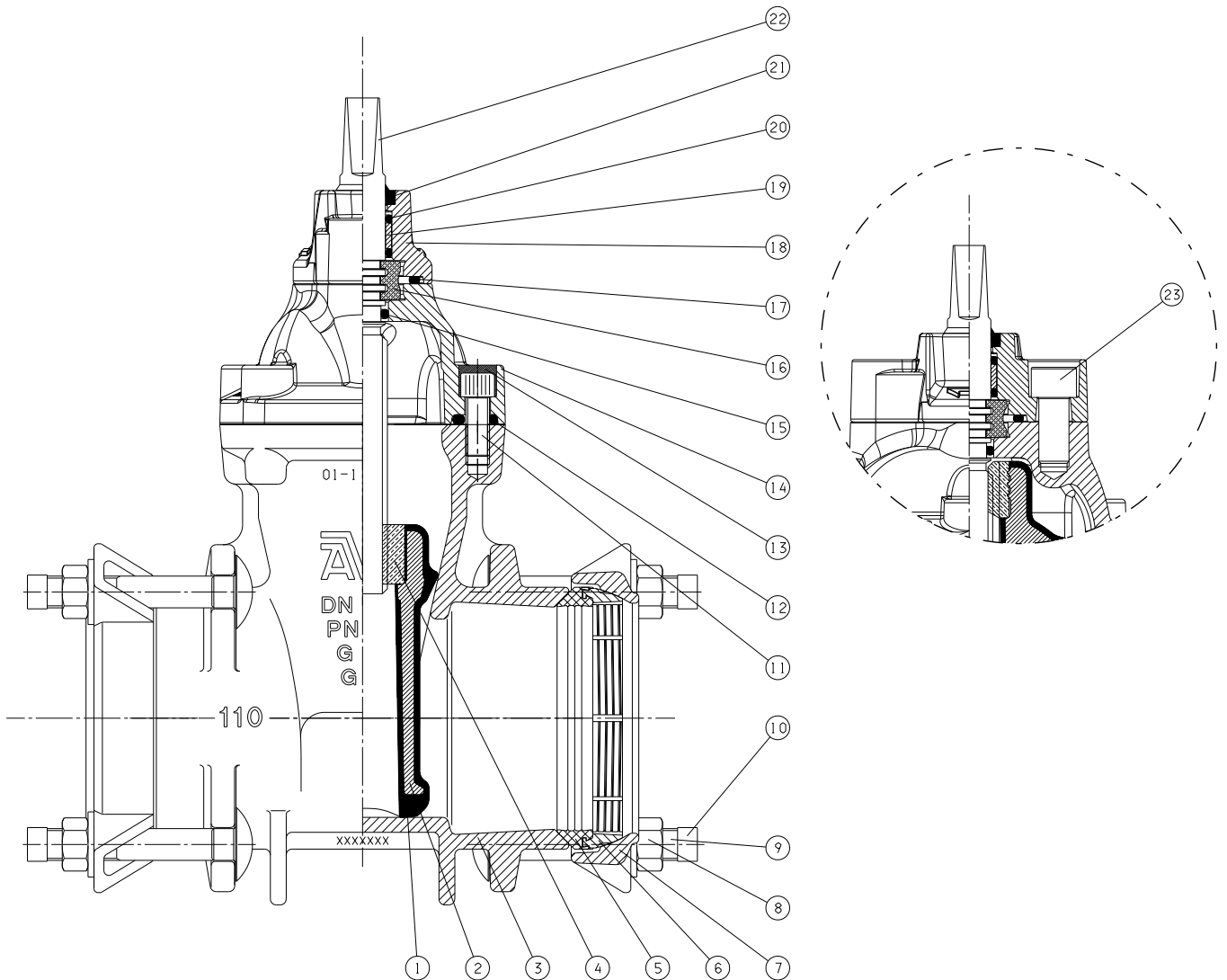

# SERIES 01/71 GATE VALVE WITH SUPA PLUS™ COUPLING FOR PE PIPE INSTALLATION, OPERATION & MAINTENANCE MANUAL

## 2. Installation

- Where valves are provided with lifting lugs, plates or eye nuts these must be used to lift the valve.
- Ensure that the fitting is compatible with the pipeline and any flange connection if appropriate.  
Note: These Supa-Plus fittings are only suitable for PE100, SDR11 polyethylene pipe/fittings.
- Examine the valve before assembling to ensure that no damage has occurred during transit.
- Examine the end of pipeline where the valve is to be assembled, ensuring that any defects such as jagged or tapered ends are restricted to within 5mm of the pipe end.
- Pipe support bushes are required when assembling these fittings onto PE pipelines. Refer AVK Installation Manual for Series 05. Check that the correct size of support bush is selected to suit both the nominal Dia. and the pressure rating of the pipeline (i.e. PE100, SDR11, PN16).
- Any protrusion of the support bush wedge once fitted can be neatly removed by hacksaw.
- Assemble the fitting over the pipe end, ensuring that a minimum pipe length of 10mm protrusion through the seal is always maintained (use necessary lubricant as appropriate).
- Align pipe end(s) maintaining the correct level and concentricity, whilst leaving sufficient gap between pipe ends to allow installation of the fitting. Ensure deflection does not exceed  $\pm 4^\circ$  per connection.
- Using a torque spanner pre-set to the recommended bolt torque, tighten diametrically opposed bolts as indicated below until the recommended bolt torque is achieved. (see chart below).

	Pipe dimension
60 Nm	DN 40 / 50 mm to DN 65 / 75 mm
110 Nm	DN 80 / 90 mm to DN 150 / 180 mm
140 Nm	DN 200 / 200 mm DN 200 / 225 mm
160 Nm	DN 250 / 250 mm DN 250 / 280 mm
200 Nm	DN 300 / 315 mm

### Bolt Torquing Sequence

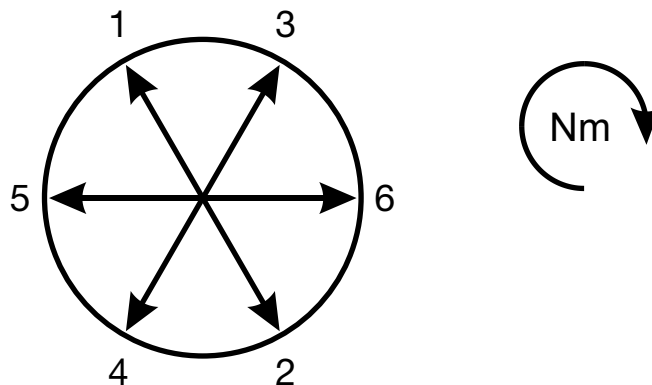

## SERIES 01/71 GATE VALVE WITH SUPA PLUS™ COUPLING FOR PE PIPE INSTALLATION, OPERATION & MAINTENANCE MANUAL

### 3. Operation

Series 01/71 valves are suitable for use with clean water or neutral liquids up to 70°C. Minimum liquid temperature must be above freezing. Insulation is essential for external temperatures on 0°C to - 10°C. The valves can be operated manually by either ring key and bar, tee key, handwheel, gearbox or electric actuation.

SIZE mm	No. of turns to fully open or close (without gearbox)	★ Maximum functional torque to achieve closure in Nm
DN80	8	75 Nm
DN100	9	100 Nm
DN150	14	150 Nm
DN200	18	200 Nm
DN225	19	200 Nm
DN250	22	250 Nm
DN300	26	300 Nm

# SERIES 01/71 GATE VALVE WITH SUPA PLUS™ COUPLING FOR PE PIPE INSTALLATION, OPERATION & MAINTENANCE MANUAL

## 4. Maintenance

The valve is designed for underground use with minimum maintenance and requires no lubrication.

In the event of a spares replacement becoming necessary the recommended procedure is as follows:

### 4.1 Replacement of Handwheel

#### Component list

1. Wedge-rubber	7. Bracket	13. Screw cover	19. Bushing
2. Wedge-casting	8. Nut	14. Bonnet	20. O-ring
3. Body	9. Square neck bolt	15. O-ring stem seal	21. Wiper ring
4. Stem nut	10. Cap	16. Stem collar	22. Stem
5. Gasket	11. Bonnet bolt	17. Gland O-ring	23. Gland bolts
6. Tensile ring	12. Bonnet gasket	18. Gland flange	

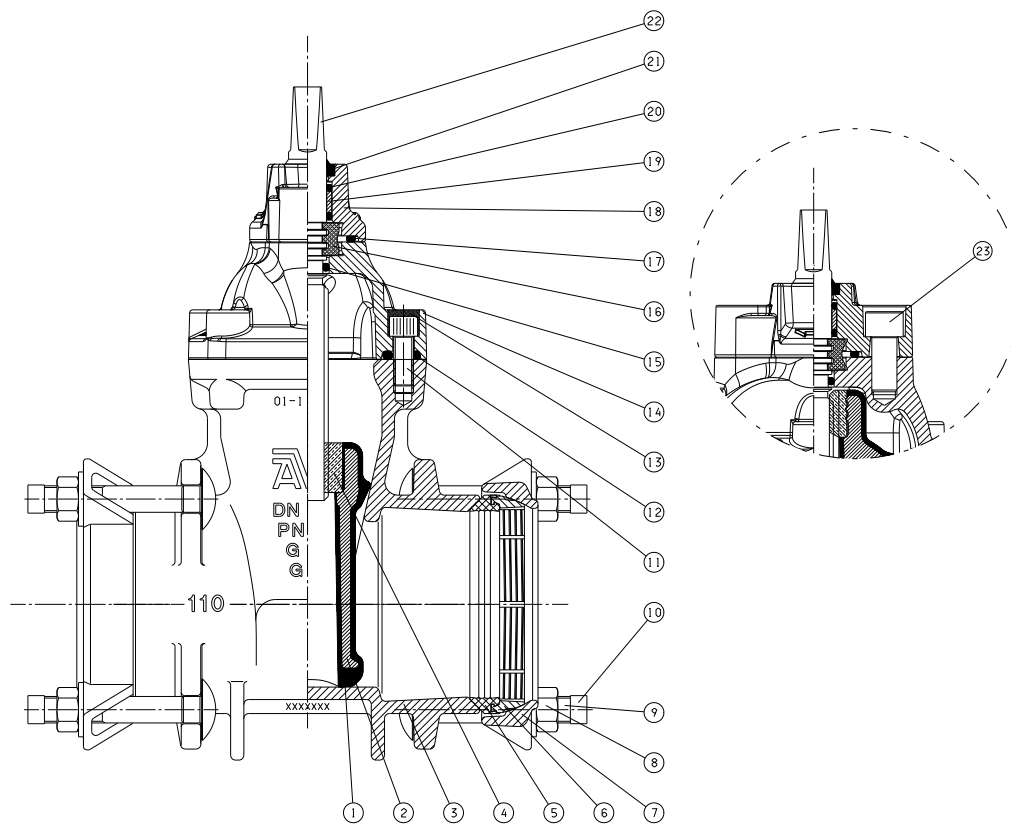

This can be carried out with valve under pressure in the pipeline, but take care over step 'a' to ensure a seal is formed between wedge and bonnet.

- Fully open valve to ensure it is back-seated.
- In the case of a stem cap being fitted carefully prise out plastic insert. Remove stem cap bolt and stem cap.
- Remove 2 gland bolts (23) on top of gland flange (18).
- Gland flange (18) can now be lifted clear of stem (22) allowing access to the stem sealing arrangement. Lift clear of stem and replace the 2 'O' (20) Rings. Refit bushing (19) on stem taking care not to nip or tear the new 'O' Rings.
- Refit gland flange (18) with a new gland flange 'O' Ring (17) and tighten the 2 gland bolts (23) using a torque wrench set at 35 Nm.
- Refit stem cap assembly.
- Close wedge by a few turns and check the integrity of the new seal arrangement.

# SERIES 01/71 GATE VALVE WITH SUPA PLUS™ COUPLING FOR PE PIPE INSTALLATION, OPERATION & MAINTENANCE MANUAL

## 4.2 Replacement of Wedge

### Component list

1. Wedge-rubber	7. Bracket	13. Screw cover	19. Bushing
2. Wedge-casting	8. Nut	14. Bonnet	20. O-ring
3. Body	9. Square neck bolt	15. O-ring stem seal	21. Wiper ring
4. Stem nut	10. Cap	16. Stem collar	22. Stem
5. Gasket	11. Bonnet bolt	17. Gland O-ring	23. Gland bolts
6. Tensile ring	12. Bonnet gasket	18. Gland flange	

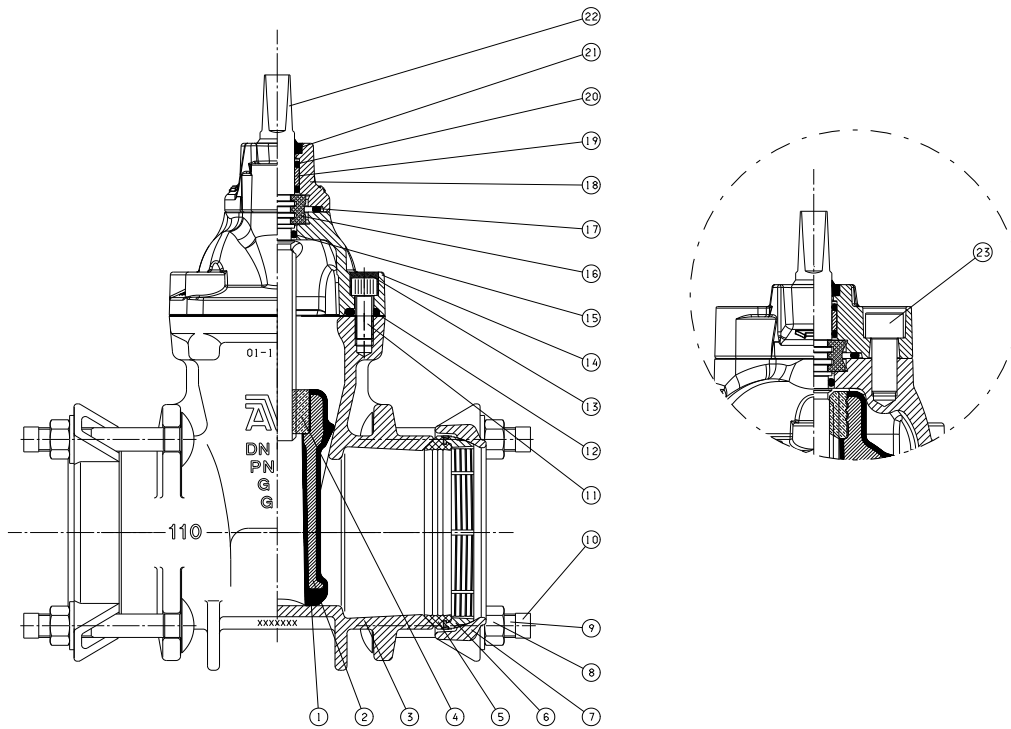

- Isolate valve and ensure there is no pressure in the pipeline.
- Adjust handwheel or stem cap to put the wedge into a slightly open position.
- Remove hot melt/screw cover (13) to expose bonnet bolts (11) then remove bolts.
- Lift the entire bonnet assembly (14) and wedge (1) clear of valve body (3).
- Unscrew wedge (1) from the stem (22).
- Fit new wedge by reversing step 'e', take care that the wedge is in a mid-position on the stem so that when refitting it will be clear of the base and body.
- Replace bonnet gasket (12). It is suggested that the bonnet bolts (11) are inserted into the bonnet holes first and then the gasket (12) is fitted over them. The whole bonnet assembly can now be refitted onto the body (3).
- Tighten the bonnet bolts (11) following a diagonal sequence and using a torque wrench set at 25 Nm to 30 Nm. Re-set the torque wrench at 40 Nm to 50 Nm and re-tighten the bolts following a circumferential sequence.
- Check integrity of seal by re-charging the main.
- Should any leakage be found, tighten bonnet bolts (11) following the diagonal sequence as in h) with the torque wrench set at 75 Nm for stainless steel bolts, 60 Nm for Grade 8.8 and 12.9 bolts.
- We recommend that the bonnet bolt heads are re-sealed to prevent corrosion. Ensure the sealant is water resistant by using, for example, a silicone type sealant.

**NOTE: It is vitally IMPORTANT to ensure all air is vented prior to fully charging the main.**

# SERIES 01/71 GATE VALVE WITH SUPA PLUS™ COUPLING FOR PE PIPE INSTALLATION, OPERATION & MAINTENANCE MANUAL

## 4.3 Replacement of Stem Seal 'O' Ring (Item 15)

### Component list

1. Wedge-rubber	7. Bracket	13. Screw cover	19. Bushing
2. Wedge-casting	8. Nut	14. Bonnet	20. O-ring
3. Body	9. Square neck bolt	15. O-ring stem seal	21. Wiper ring
4. Stem nut	10. Cap	16. Stem collar	22. Stem
5. Gasket	11. Bonnet bolt	17. Gland O-ring	23. Gland bolts
6. Tensile ring	12. Bonnet gasket	18. Gland flange	

- Isolate valve and ensure there is no pressure in the pipeline.
- Turn keyed stem to put the wedge into a slightly open position.
- In the case of a stem cap being fitted carefully prise out plastic insert. Remove stem cap bolt and stem cap.
- Remove 2 gland bolts (23) on top of gland flange (18).
- The gland flange (18) can now be lifted clear of stem (22) allowing access to the stem seal arrangement.
- Fully close the valve in order to raise the stem (22) clear of the bonnet (14) ensuring that the two stem collars (16) are retained for re-assembly.
- Remove stem seal 'O' ring (15) and replace with a new 'O' ring (15), grease the 'O' ring with Water Regulations approved grease e.g. Rocol Aqua-Sil.
- Replace the two 'O' rings (17) and nylon bushing (19) in the gland flange (18). Grease internally using the approved grease. Grease thrust collar grooves in stem (22). Screw stem (22) back into wedge (1) whilst fitting stem collars (16) ensuring they seat fully inside recess in bonnet (14).
- Refit gland flange (18) with a new gland flange 'O' ring (17) and tighten the 2 gland bolts (23) using a torque wrench set at 35 Nm.
- Refit stem cap, bolt and insert.
- Close wedge by a few turns and check the integrity of the new seal arrangement
- The check the integrity of the new seal arrangement, it will be necessary to re-charge the main slowly and open

