

FOX VALVE Washdown Diversion System

www.stormwater360.co.nz

Eliminates expensive roofing creating a more effective outdoor wash area

THE FOX VALVE DIVERSION SYSTEM from Stormwater360 is an effective control device for any unroofed washdown area automatically diverting wash water as well as the 'first flush' (if required) to sewer or treatment, whilst allowing unpolluted rain water to enter the stormwater network.



At the heart of the Stormwater360 Fox Diversion System is a Fox Demand valve which is fitted inline before the wash point and the Fox Diversion Valve, which comes fitted in a range of varied pit sizes or can be set up on 10mm Marine grade Aluminium plate to suit custom formed concrete pits.

HOW DOES IT WORK?

A hydraulic signal is sent from the demand valve to the diversion valve when washdown commences, automatically opening the diversion valve protecting the environment from contaminated wastewater.

At the end of the washdown operation the diversion valve will automatically close, allowing rainwater to exit through the stormwater outlet, avoiding flooding of the treatment system, which then leads to the subsequent local sewer network.

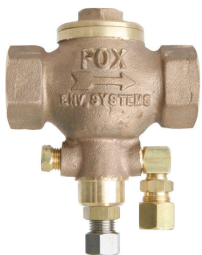
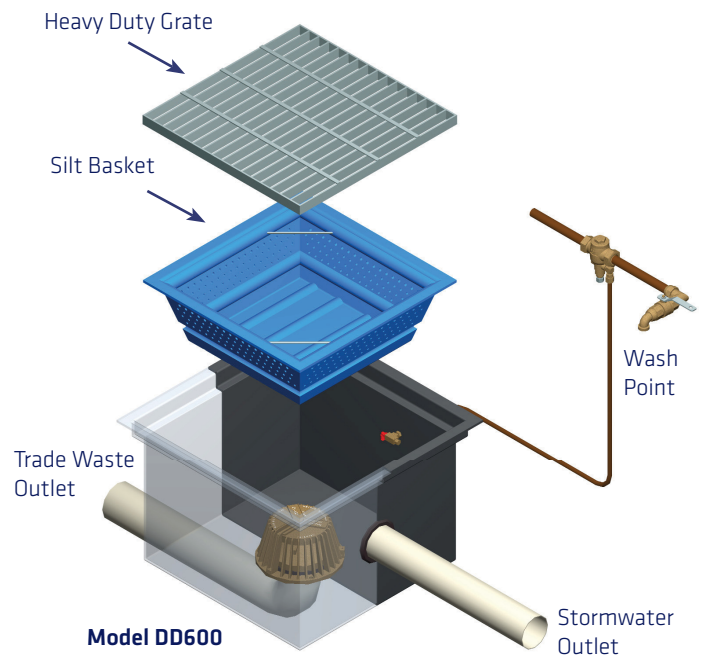

FOX Demand Valve DMV25



FOX Diversion Valve DV150



Polyethylene chamber, grate and galvanised steel mesh stone basket



APPLICATIONS

- Bin & car wash facility
- Machinery washdown
- Mechanical workshops
- Parts washing
- Marinas & slipways
- Truck washdown
- Rail yards
- Vehicle dealerships
- Kennels
- All wash applications

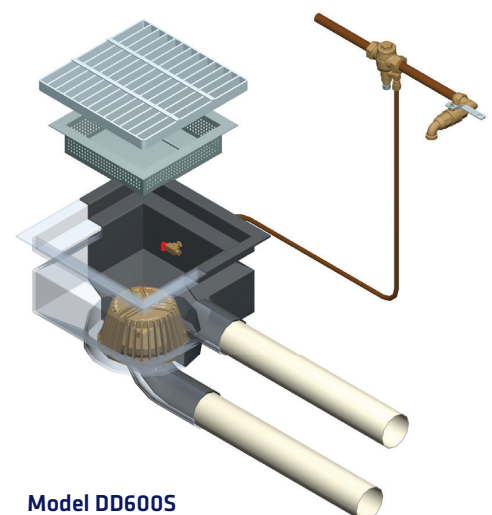

FOX VALVE First Flush System

www.stormwater360.co.nz

Demand driven diversion unit providing additional environmental protection

THE FOX VALVE FF600 SYSTEM from Stormwater360 is a demand driven diversion unit that provides additional protection for the environment when no washdown is taking place. It is designed for use in areas where there is no guarantee that the wash bay will be left clean at the completion of a wash activity. Pollutants remaining on exposed areas can be dislodged by rain and carried into the stormwater network. The Fox FF600 is designed to cleanse a site by capturing the initial runoff and diverting it to suitable treatment, as it is most likely that this initial runoff will carry with it any residual pollutants that have been left on the site.



The unit is fitted in a polyethylene chamber with a 600 square medium duty grate. A polyethylene silt basket is fitted below the grate to capture silts, solids and free floating debris. This is removable for disposal of the captured pollutants. A Fox Model DV150 stormwater diversion valve is installed in the bottom of the chamber.

HOW DOES IT WORK?

Runoff enters the Fox FF600 chamber via the grated inlet and silt basket. During a wash operation all runoff is diverted to a holding tank for treatment or proper disposal. During a rain event if no washdown is taking place, the level in the chamber will rise as the diversion valve is closed. At a point just below the stormwater outlet a float will activate, opening the diversion valve and diverting the pit contents to the treatment tank or sewer. This procedure will continue until the required 'First Flush' volume has been diverted. After the 'First Flush' has been taken, discharge of the runoff will be through the stormwater outlet pipe. This arrangement eliminates the larger volumes of runoff that are normally collected with a conventional First Flush capture system.

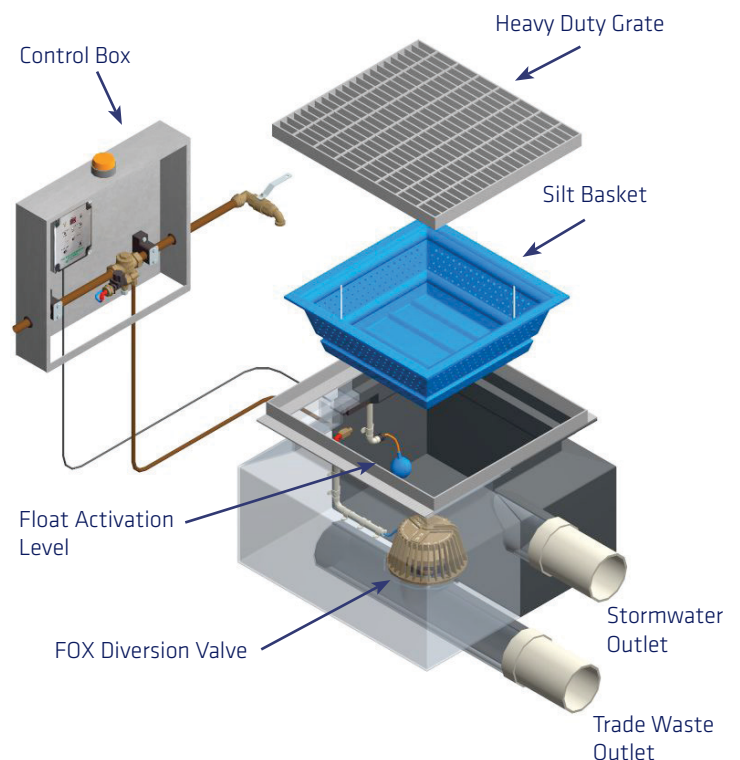

SYSTEM CONTROL PANEL

A Control Panel is supplied containing all electrical control equipment as well as the Fox Demand Valve.

All washpoints must come from beyond this Panel Box. A water supply (min. 100 kPa) and 240 v AC power are required for the control panel which should be installed in a convenient location near the system.

A 13mm copper drive line and a 32mm electrical conduit are required between the control panel and the FF600 chamber. The 13mm copper drive line is the signal line that will activate the diversion of the unit when a demand for wash water is detected.

CONTACT DETAILS

Stormwater360

FREEPHONE:
0800 STORMWATER
(0800 786769)

www.stormwater360.co.nz

Stormwater360
BETWEEN SKY AND SEA

FOX Spill Control System

Protection against spills
of water soluble products

When your site has the potential to have stormwater run-off that has been contaminated with water-soluble products such as wines, milk or chemicals entering the waterways there is a need for a Stormwater360 Fox Spill Control System. The system monitors all site run-off for pollutant concentrations that exceed predetermined levels. Ideally suited to installations where there is a risk of hydrocarbon spills contaminating the stormwater network. The system is designed to allow site run-off to flow to the stormwater network while constantly monitoring the quality.



HOW DOES IT WORK?

The unit is fitted in a polyethylene chamber with a 600 square medium duty grate. A polyethylene silt basket is fitted below the grate to capture solids and free floating debris. This is removable for disposal of the captured pollutants. A water quality sensor installed in the chamber detects the presence of any dissolved pollutants and can be calibrated to match site requirements.

At the commencement of rain the chamber fills to a level where the float is activated. As a cleansing procedure the system will divert the first rain to four chambers (site specific) contents without activating the probe. After the first volume of run-off has been diverted the sensor probe will be activated each time the float is triggered and the quality of the runoff is checked before being released.

If the level of pollutants is of a concentration that is not suitable to be discharged to stormwater an alarm will be activated and the pit contents will be diverted to a holding tank. This process continues until the water quality is suitable to be discharged to the stormwater system.

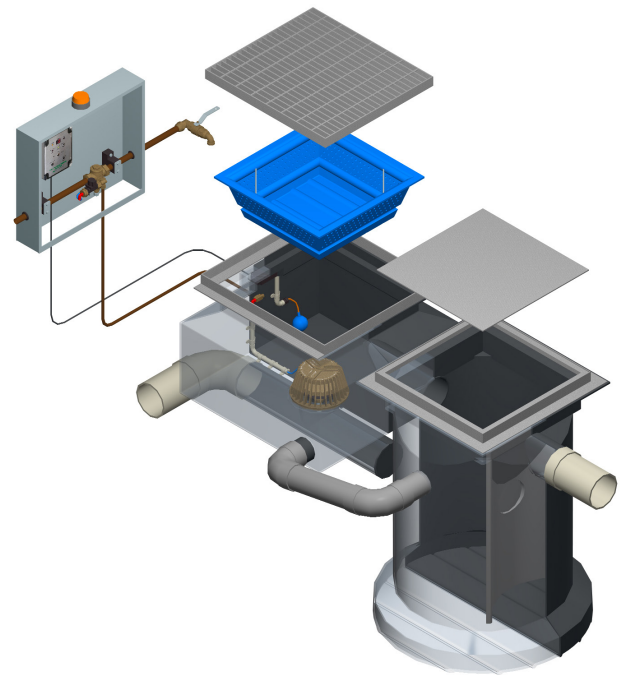

KEY USAGE

Ideally suited to installations such as bulk liquid storage facilities, Service Stations, refuelling areas or any site where there is a risk of hydrocarbon spills contaminating the stormwater network.

CONTACT DETAILS

Stormwater360

FREEPHONE:
0800 STORMWATER
(0800 786769)

www.stormwater360.co.nz

Stormwater360®
BETWEEN SKY AND SEA