



AVK SINGLE ORIFICE AIR RELEASE VALVE PN16

851/00



Single Orifice air release valve PN16 & PN25
Inlet 25mm BSP female



Use:

- For water (not sewage) and neutral liquid applications
- Valve designed for use up to 70°C
- Where applicable for AS 4020 compliance, max temp = 40°C



Tests:

- Hydraulic test: 1.5 x PN

Optional extras:

- Isolating valve



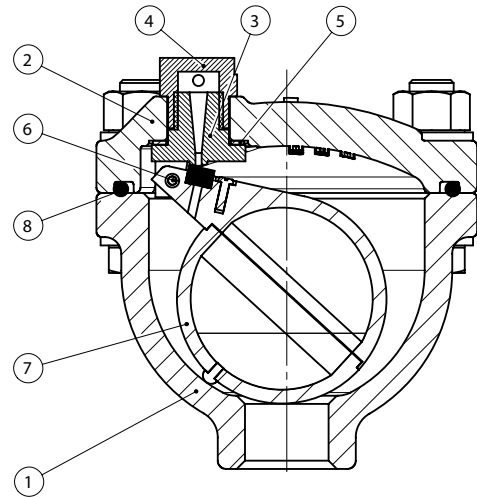
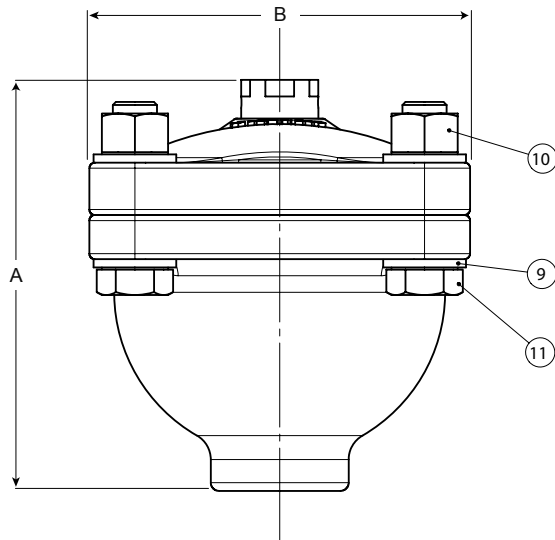

Component list

1. Body	Ductile Iron BS EN 1563 EN-GJS 500/7	7. Float	Plastic ABS
2. Cover	Ductile Iron BS EN 1563 EN-GJS 500/7	8. O-ring	Stainless Steel 316 Grade A4
3. Orifice bracket	Nylon	9. Washer	Stainless Steel 316 Grade A4
4. Orifice cover	Nylon	10. Nut	Stainless Steel 316 Grade A4
5. Gasket	EPDM WBS listed	11. Hex bolt	Stainless Steel 316 Grade A4
6. Grooved pin	Stainless Steel 316 Grade A4		

Components can be substituted with equivalent or higher class materials.

Reference nos. and dimensions

AVK ref nos.	DN mm	Ends	A mm	B mm	Approx weight kilos
PN16					
851-025-00822000	25	BSP	151	138	6.2
PN25					
851-025-00822009	25	BSP	151	138	6.2