

Stormwater collection products for all NZ stormwater specifications



Designs to meet your local requirements

Stormwater drainage is an essential task, with the need to convey water from the sides of roads into drains or underground pipelines. Humes supply a variety of products used in the overall stormwater collection process.

Because of the variety of specifications that exist for stormwater drainage products throughout New Zealand, not all products are shown in this brochure.

Please approach your local Humes Sales Centre for more detailed data on further products and sizes available in your region.

Features

- Specifically designed units meet local body requirements
- Various efficiencies and capabilities to achieve optimum design

Benefits

- Humes stormwater products save money by being designed for efficient construction
- Humes stormwater products require no moulds or formwork
- Quality control manufacturing ensure consistent, dependable construction
- Humes stormwater products can be installed in half the time as insitu units
- Humes stormwater products are designed for easy installation reducing on-site labour costs

Applications

- Subdivisions – residential and commercial
- Major capital roading projects
- Municipal accessways





Max pit

The Max pit in conjunction with the Manning grate has been designed to maximise the capture efficiency of the catchpit. A full set of comprehensive design and performance data can be made available upon request.

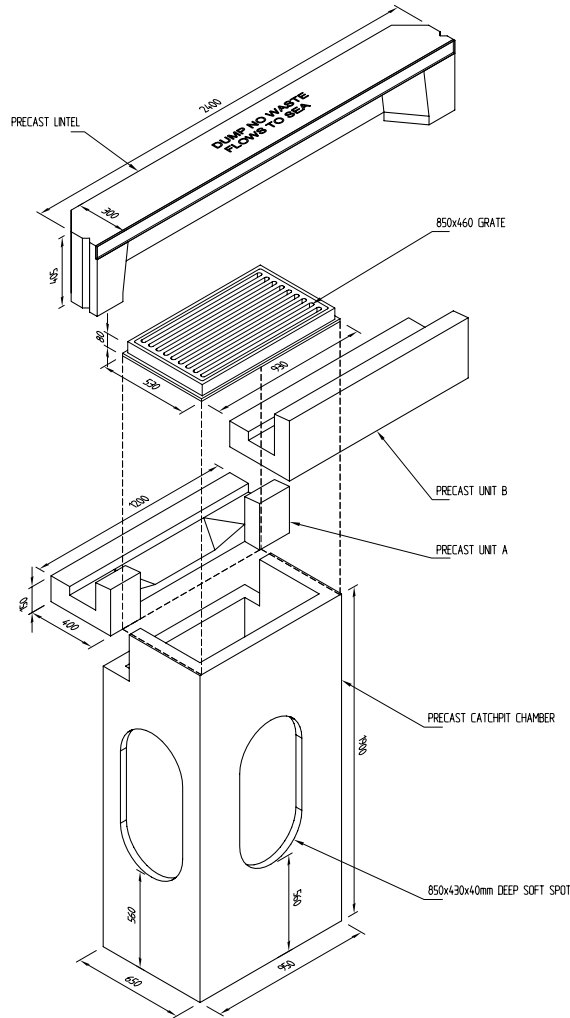

Max pit catchpit configuration available in long (shown above) and short lintel

Lintel type	Overall length	Precast unit B
Short lintel	1200mm	not required
Long lintel	2400mm	required

Max pit

Item	W	D	H	Weight
Sump	950	650	1900	1225
Unit A	1200	400	150	125
Unit B	1200	400	150	200
Short lintel	1200	300	405	225
Long lintel	2400	300	405	400

Flat top cesspit

The standard Humes cesspit comprises of a precast concrete chamber with cast iron frame and grate.

Short length risers can be supplied to increase the cesspit depth if required.

The standard chamber has nominal internal dimensions of 450 x 450mm; length 1200mm with 75mm wall thickness. Standard chambers are supplied with cast in floors, but open units can be made to the clients order. Soft spots are formed in the walls.

Riser sections of 300mm height are available to increase the cesspit depth if required.

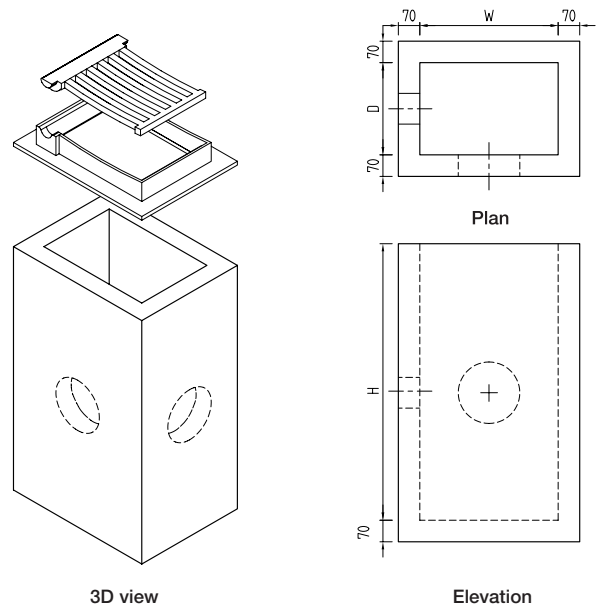

Cess pit sizes	W	D	H	Total mass weight
Cess pit	300	300	630	172 kg
Cess pit	450	300	630	245 kg
Cess pit	450	300	900	344 kg
Cess pit	450	450	900	404 kg
Cess pit	450	450	1200	568 kg
Cess pit	675	450	1200	621 kg
Cess pit	675	450	1650	900 kg

* Manufactured in Papakura and Alexandra.



Flat top cesspit



Back entry cesspit

The back entry cesspit comprises a precast concrete chamber with cast iron frame and grate; and a precast back inlet block.

Short length risers can be supplied to increase the cesspit depth if required.

Cast iron or steel back inlets can also be supplied as an alternative to the concrete inlet unit.

The standard chamber has nominal internal dimensions of 675 x 450mm; length 1220mm with 75mm wall thickness. An intake opening in the back of the unit is provided and soft spots are formed. Swiftlift anchors holes can also be incorporated for handling.

Chambers can be supplied with or without floors. This should be specified when ordering.

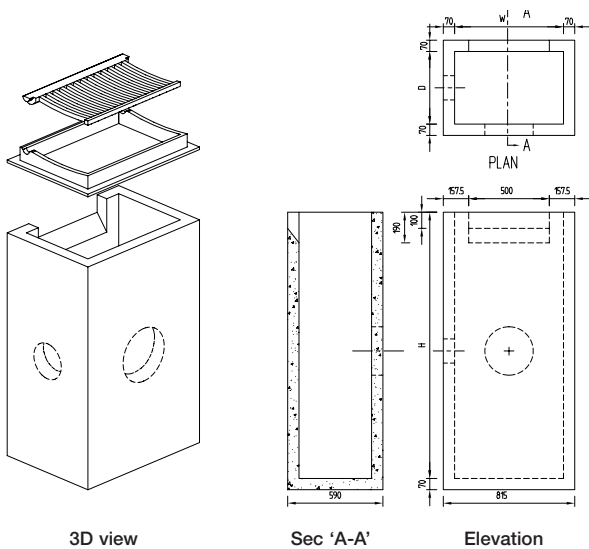

3D view

Sec 'A-A'

Elevation

Cesspit sizes	W	D	H	Total mass weight
Cesspit	675	450	1200	621 kg
Cesspit	675	450	1650	900 kg

Cesspit risers

Cesspit risers are available for greater depth.

Riser sizes	H	W	D	Total mass weight
450 x 450 x 300	300	450	450	106 kg
675 x 450 x 300	300	675	450	152 kg
675 x 450 x 600	600	675	450	257 kg

* Manufactured in Papakura and Alexandra.

Catchpit slab

This precast catchpit has been designed to provide uninterrupted kerblines with off road cleaning access. Because of the side entry system cast iron frames and grates are not required resulting in a neat uncluttered channel surface safe for cyclists and easy to clean. No grate to become clogged with leaves and litter.

The slab fits over a 750mm diameter riser.

Apart from the standard kerb type there is a mountable and bullnose slab type available.

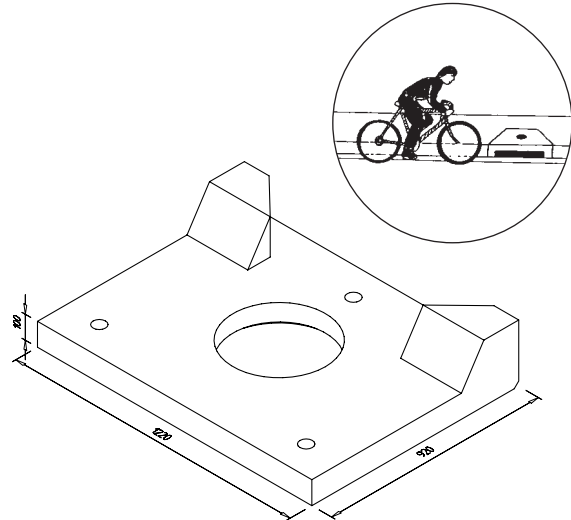

3D view of catchpit slab shown upside down

Catchpit slab

Item	W	D	H	Weight
Slab	1220	920	225	264

* Manufactured in Papakura.



Back entry cesspit



Yard sump

Humes precast yard sumps are designed for surface drainage of school playgrounds, car parks, sealed sports areas and situations where surface water is a problem.

The unit consists of a heavy duty reinforced concrete top with cast iron frame cast in. It is 890 x 725mm with a 25mm deep recess on bottom.

The precast top is recessed on the underside for accurate location in a circular Humes spun pipe. The pipe measures 600mm in diameter and is available in varying lengths to suit offtake drainage pipe depth. (Other configurations are available to suit 300mm and 450mm diameter mini sumps).

Masses: Sump top complete with frame and grate 216.3kg;
Riser 230kg per metre.

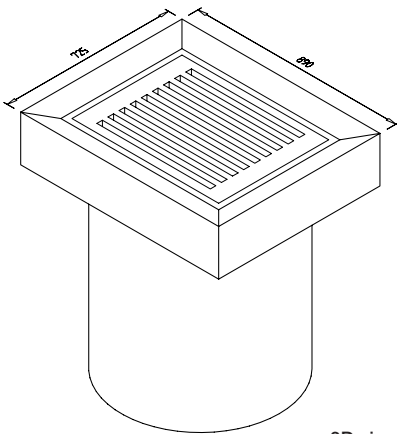

3D view of Yard Sump

Yard sump top

Item	W	D	H	Weight
Sump top	890	725	180	135

* Manufactured predominantly in Hastings.

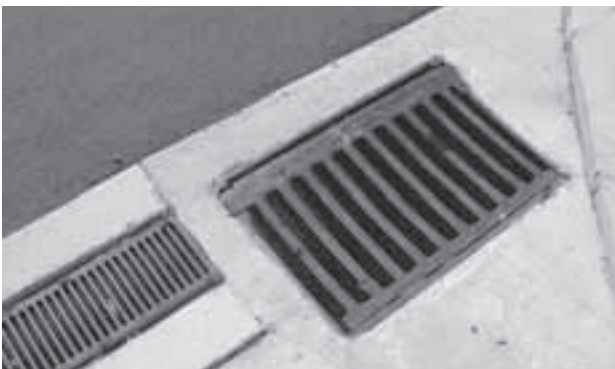

Yard sump with surface drain

WCC unit

Unit designed by the Wellington City Council. Consists of a rectangular sump unit with tapered sides. Lifting holes are cast in for ease fitting of inlet and outlet pipes. Special recesses have been designed to accommodate the baffle and cleaning eye slab. Fittings supplied include cast iron cleaning eye with frame, sump and kerb block.

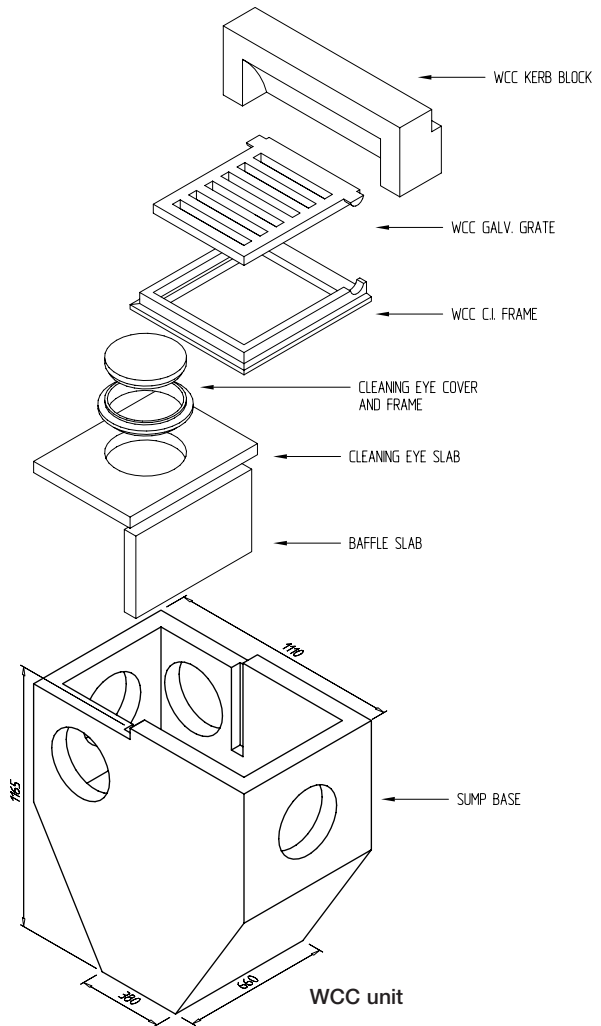

WCC unit

Item	W	D	H	Weight
Sump	1110	660	1165	917

* Manufactured at the Hastings Plant for the Wellington area.



Mudtank

The rectangular street mudtank comprises a precast concrete chamber with a standard length of 1290mm, cast iron frame and grate and a precast concrete cover.

The chamber has nominal internal dimensions of 1090 x 380 x 1000mm with 100mm thick walls. Soft spots are formed at one end. Swift lifts are incorporated for easy lifting. Mass 1000kg.

Standard heavy duty cast iron frame and grate have an opening of 560 x 310mm. Mass 110kg.

Other yard type drainage sumps include nominal internal dimensions of 550 x 550 x 900mm and 550 x 550 x 450mm both with 75mm thick walls.

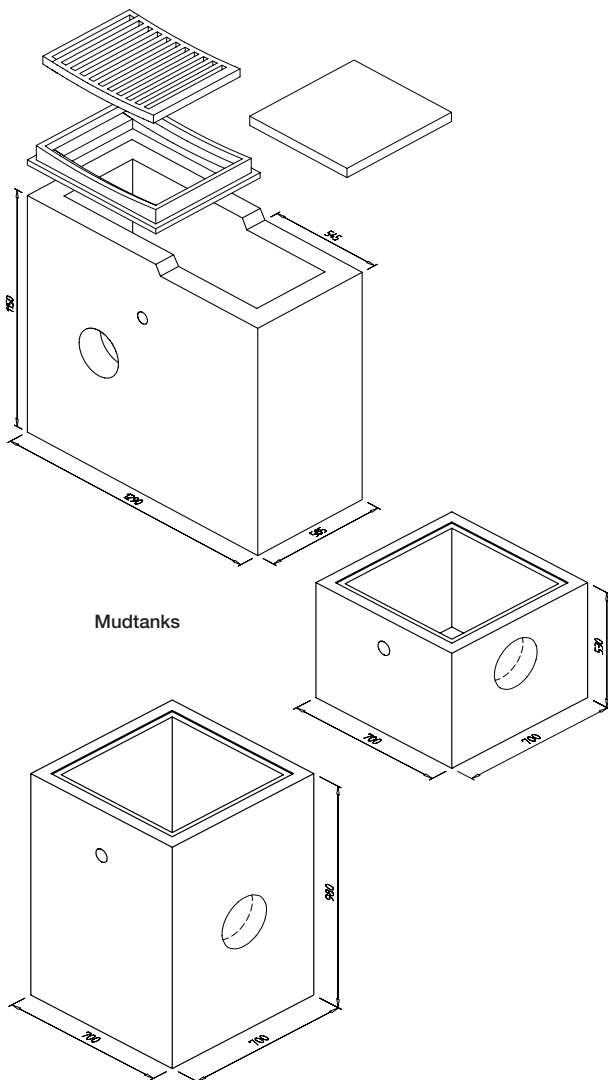

Mudtanks

Mudtank

Item	W	D	H	Weight
Standard #2	1290	585	1150	1145
Standard #3	680	470	660	297
Mudtank	700	700	530	327
Mudtank	700	700	980	488

* Manufactured in Alexandra for the lower South Island only.

Silt-traps

Rectangular precast concrete units. Available with 3 way pipeline insertions as well as unfinished.

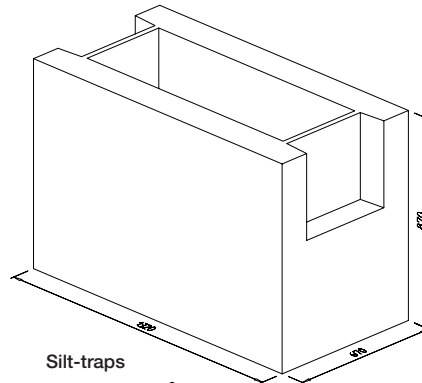

Silt-traps

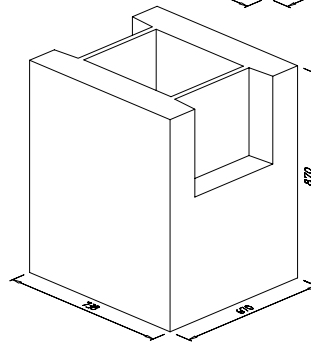

Silt trap

Item	W	D	H	Weight
Single 3 way	738	670	870	655
Double	1320	670	870	1168

* Manufactured in Christchurch for Canterbury Region.

Nelson catchpit

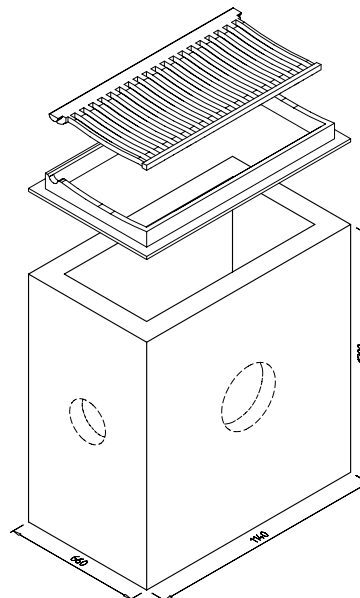

Nelson catchpit

Item	W	D	H	Weight
Sump	1140	660	1200	990

* Manufactured in Nelson for Nelson City Council.



LHCC

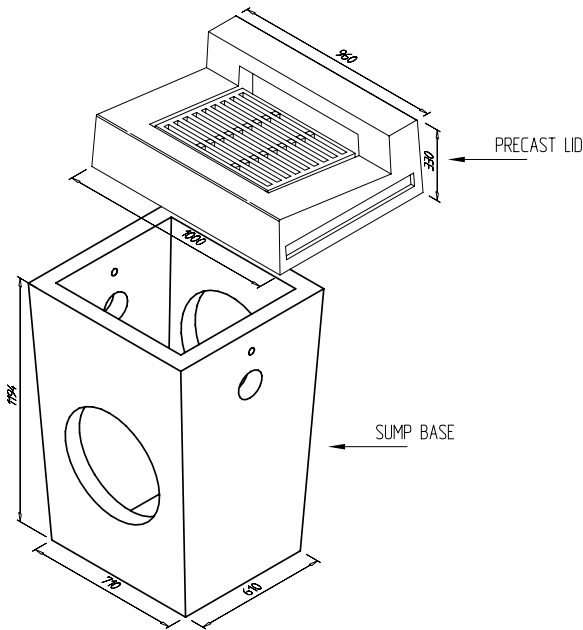

LHCC

Item	W	D	H	Weight
Sump	810	760	1194	600
Lid	1000	740	330	256

* Manufactured in Hastings for Hutt Valley and Wanganui Councils.

Ike type

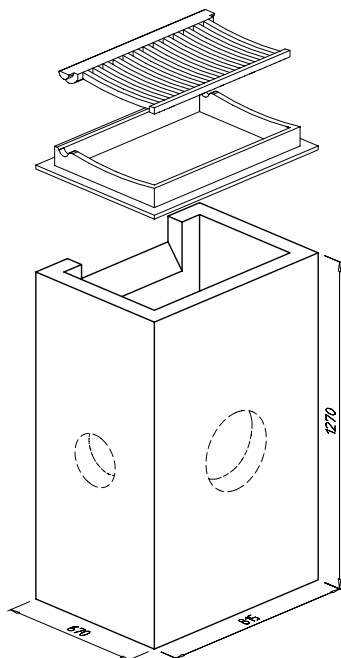

Ike type

Item	W	D	H	Weight
Sump	815	670	1270	621

* Manufactured in Papakura for Tauranga City Council.

Dimensions and masses

All dimensions stated are in mm. All weights are in kgs.

Installation

Humes catchpit componentry are supplied complete with cast iron frames and grates. Soft spots have been designed for connection to the outlet pipe.

Maintenance

There is no blanket rule for maintaining catchpits as each application will have different conditions and each governing authority will have differing expectations. It should be noted that catchpits are not designed to be stormwater treatment devices.

Manufacturing standards

Precast manufacture is to NZS 3109:1997 (**when soft spots are mortered and made good**) with surface finishes to NZS 3114:1987, F4 and U2 for formed and trowelled respectively.

For further details please contact your local Humes Sales Representative.



Cesspit installation

Buyers and users of the products described in this brochure must make their own assessment of the suitability and appropriateness of the products for their particular use and the conditions in which they will be used. All queries regarding product suitability, purpose or installation should be directed to the nearest Humes Sales Centre for service and assistance. © Fletcher Concrete and Infrastructure Limited 2006. Printed 05/06.

