



## SERIES 621, 623 & 624 SUPA PLUS™ COUPLINGS, FLANGE ADAPTORS & END CAPS INSTALLATION, OPERATION & MAINTENANCE MANUAL



### Instruction for use

Thank you for selecting an AVK product. With correct use, it will give long and reliable service. This manual has been prepared to assist you install, operate and maintain the valve to the maximum efficiency. For ease of reference, it has been divided into sections covering all aspects of use, and it is in the users best interests to read it and ensure that it is fully understood.



### Health and Safety

It is always recommended that wherever work is being carried out on a valve that the valve is fully depressurised prior to carrying it out, and for the convenience draining of the line may be beneficial.

It is essential that the user of the valve is aware of the weight of the components and/or assemblies that must be handled and manipulated during installation and maintenance. It is the users responsibility to ensure that safe working practices are followed at all times.

Whenever AVK products are installed, operated, or maintained, it is essential that the staff that undertake these operations be adequately trained. The hazards of pressurised liquids and gases can be severe, and it is the responsibility of the users to ensure that trained, competent staff undertake these duties. This manual has been designed to assist, but it can never fully replace quality training in the workplace. AVK technical staff will always be available to answer any questions relating to specific problems that may not be covered by this manual.

AVK products are designed and manufactured to be fit for purpose, and to a high and reliable standard. This provides a safe product with minimum risk to health when used correctly for the purpose for which it was designed. However, this assumes that the equipment is used and maintained in accordance with the manual, and the user is advised to study this manual, and to make it available to all staff that may need to refer to it.

AVK cannot be held responsible for any incidents arising from incorrect installation, operation or maintenance. The responsibility for this must rest wholly with the user.

# SERIES 621, 623 & 624 SUPA PLUS™ COUPLINGS, FLANGE ADAPTORS & END CAPS INSTALLATION, OPERATION & MAINTENANCE MANUAL

## 1. Introduction

AVK series 620 Supa Plus™ Couplings are available in straight barrel, flange adaptor and as an end cap.

These couplings are designed for use with PE-pipe and will provide end restraint.

These couplings should always be used in conjunction with AVK series 05, 316 Stainless Steel support bushes.

### Materials:

**Tensile ring/sealing ring**  
Gun metal / EPDM rubber

**Fasteners**  
Stainless Steel (nut PTFE coated)

**Cap**  
Plastic

**Coating**  
Fusion bonded epoxy (FBE)

**Castings (body & gland ring)**  
Ductile Iron

Refer to individual datasheets for specific information



**SERIES 621, 623 & 624 SUPA PLUSTM COUPLINGS, FLANGE ADAPTORS & END CAPS  
INSTALLATION, OPERATION & MAINTENANCE MANUAL**

**Component list - Series 621**

- |                         |            |        |                     |
|-------------------------|------------|--------|---------------------|
| 1. Sleeve               | 3. Bracket | 5. Nut | 7. Square neck bolt |
| 2. Tensile sealing ring | 4. Washer  | 6. Cap | 8. Support bush     |

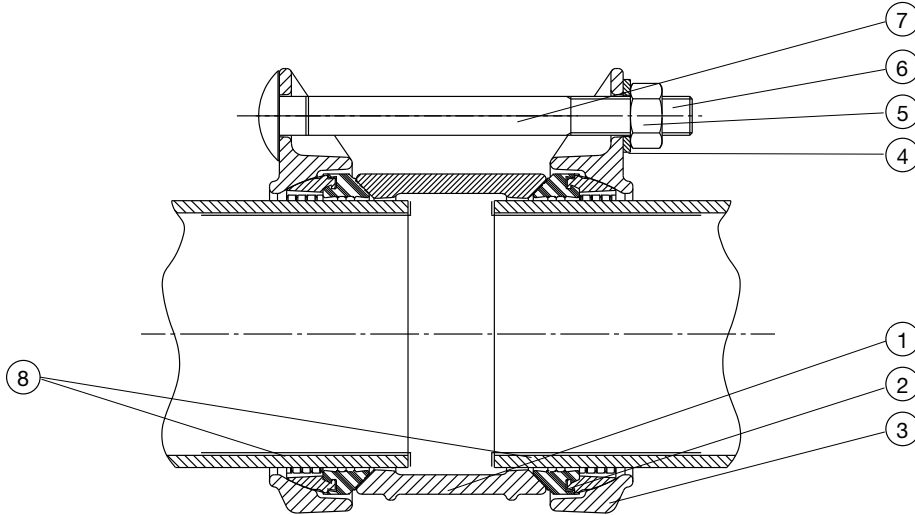

**Component list - Series 623**

- |                         |             |                     |                 |
|-------------------------|-------------|---------------------|-----------------|
| 1. Tensile sealing ring | 3. Bracket  | 5. Washer           | 7. Cap          |
| 2. Adaptor flange       | 4. Hex. nut | 6. Rectangular bolt | 8. Support bush |

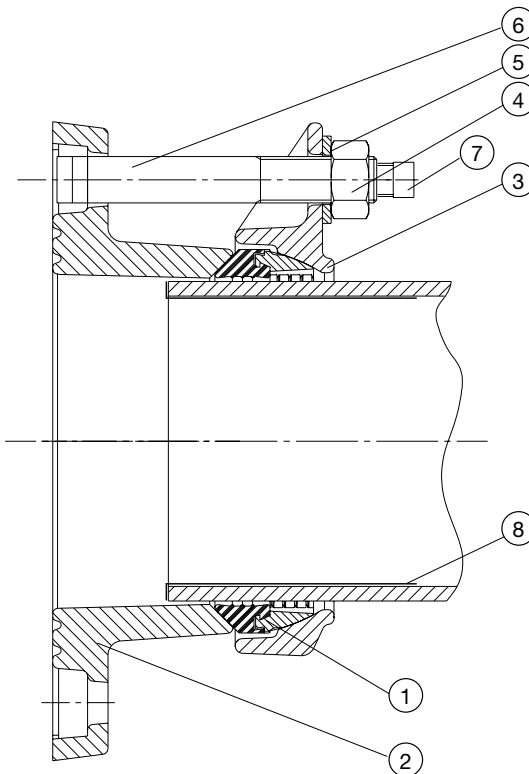

**SERIES 621, 623 & 624 SUPA PLUSTM COUPLINGS, FLANGE ADAPTORS & END CAPS  
INSTALLATION, OPERATION & MAINTENANCE MANUAL**

**Component list - Series 624**

1. Body  
2. Gasket

3. Tensile ring  
4. Bracket

5. Nut  
6. Bolt

7. Cap

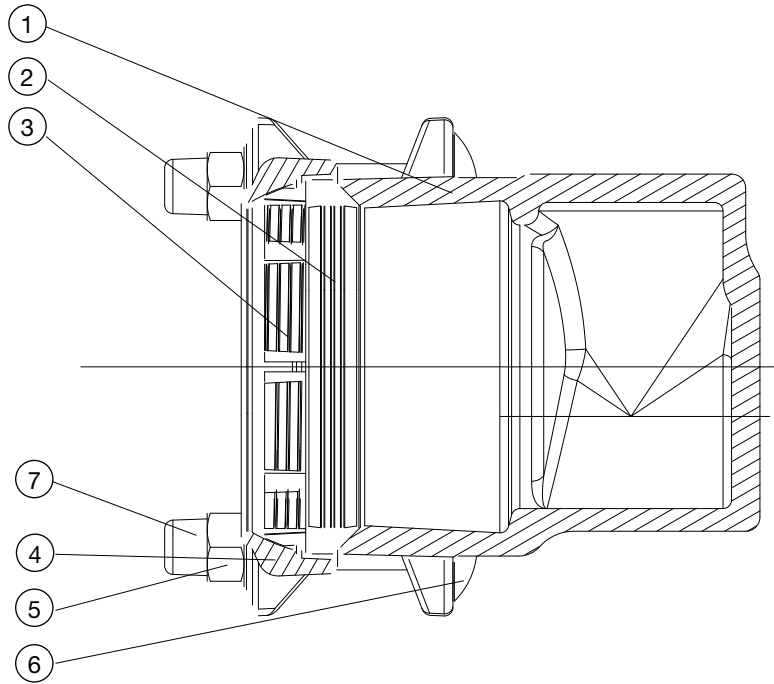

**SERIES 621, 623 & 624 SUPA PLUSTM COUPLINGS, FLANGE ADAPTORS & END CAPS  
INSTALLATION, OPERATION & MAINTENANCE MANUAL**

**2. Installation**

- Ensure that the fitting is compatible with the pipeline and any flange connection if appropriate.  
Note: These Supa-Plus fittings are only suitable for PE100, SDR11 polyethylene pipe/fittings.
- Examine the fitting before assembling to ensure that no damage has occurred during transit.
- Examine the end of pipeline where fittings are to be assembled, ensuring that any defects such as jagged or tapered ends are restricted to within 5mm of the pipe end.
- Pipe support bushes are required when assembling these fittings onto PE pipelines. Refer AVK Installation Manual for Series 05. Check that the correct size of support bush is selected to suit both the nominal Dia. and the pressure rating of the pipeline (i.e. PE100, SDR11, PN16).
- Any protrusion of the support bush wedge once fitted can be neatly removed by hacksaw.
- Assemble the fitting over the pipe end, ensuring that a minimum pipe length of 10mm protrusion through the seal is always maintained (use necessary lubricant as appropriate).
- Align pipe end(s) maintaining the correct level and concentricity, whilst leaving sufficient gap between pipe ends to allow installation of the fitting. Ensure deflection does not exceed  $\pm 4^\circ$  per connection.
- Using a torque spanner pre-set to the recommended bolt torque, tighten diametrically opposed bolts as indicated below until the recommended bolt torque is achieved. (see chart below).

**Bolt Torque Chart**



	Pipe dimension
60 Nm	DN 40 / 50 mm to DN 65 / 75 mm
110 Nm	DN 80 / 90 mm to DN 150 / 180 mm
140 Nm	DN 200 / 200 mm DN 200 / 225 mm
160 Nm	DN 250 / 250 mm DN 250 / 280 mm
200 Nm	DN 300 / 315 mm

**Bolt Torquing Sequence**

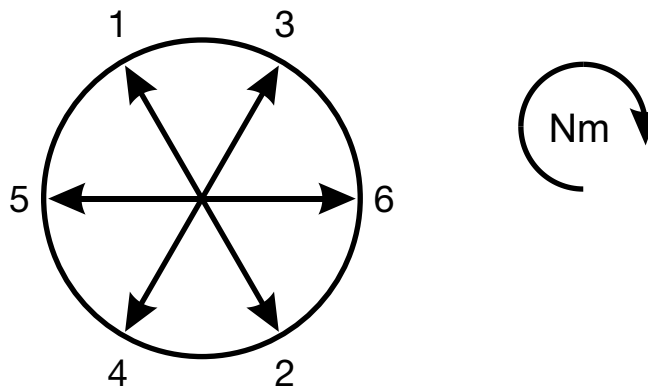

Note: S/S fasteners should not be reused.

## SERIES 621, 623 & 624 SUPA PLUSTM COUPLINGS, FLANGE ADAPTORS & END CAPS INSTALLATION, OPERATION & MAINTENANCE MANUAL

### FLANGE CONNECTIONS

- When installing flange adaptors ensure the flange faces are clean.
- To ensure adequate sealing it is important to select the correct type of gasket for the medium concerned, gaskets with the correct flange size must be used.
- Tighten flange bolts loosely.
- Tighten bolts in a diagonal sequence to ensure flanges are pulled up parallel.
- Finally tighten bolts to correct torque levels as recommended in WSA 109 specification.

#### Flange bolt size

The following table shows the bolt sizes you should use for the DN flange dimensions.

DN	AS 4087 Table B5		AS 2129 Table E	
	Bolts	Quantity	Bolts	Quantity
50	M16	4	M16	4
80	M16	4	M16	4
100	M16	4	M16	8
150	M16	8	M20	8
200	M16	8	M20	8
225	M16	8	-	-
250	M16	8	M20	12
300	M20	12	M24	12
375	M24	12	M24	12
400	M24	12	M24	12