



AVK STUBBE PE100 BALL VALVE, PN10, SDR 11 FOR GAS

85/50

PE100 ball valve with spigot ends for gas -20°C to +40°C

Standards:

- Designed according to EN 1555-4. Designed according to DVGW VP 302

Tests:

- Valve Hydraulic test to EN 1555-4, EN ISO 1167-1 and EN ISO 1167-4

Approvals:

- Approved according to DVGW Certificate DG-4394CM0169
- Approved according to DVGW EC Certificate CE-0085CL0505
- Approved according to KITE MARK, Licence Number KM 557310

Features:

- All main parts are of PE100 ensuring equal expansion and/or shrinkage of components due to temperature influence and thus that their interfacing tolerances remain intact
- Stem on POM sealed by two NBR O-rings and a bearing ring of yellow PE with indication of 'PE ball valve', 1/4", and open/close direction
- The connector is replaceable under pressure and as a safety feature designed to fail and prevent leakage if the valve is over torqued
- Expansion grooves around the stem from DB50/Ø63mm and in the spigot ends from DN65/Ø75mm contribute to low operating torques and adapt to any deformation caused by internal pressure
- The PE ball surface combined with the high quality rubber seals and a special grease also contribute to low operating torques and prevent sticking
- Full traceability of all parameters, components and raw materials

Accessories:

- Telescopic extension spindles
- Welded stem connection with purge points and support base up to DN80/Ø90mm



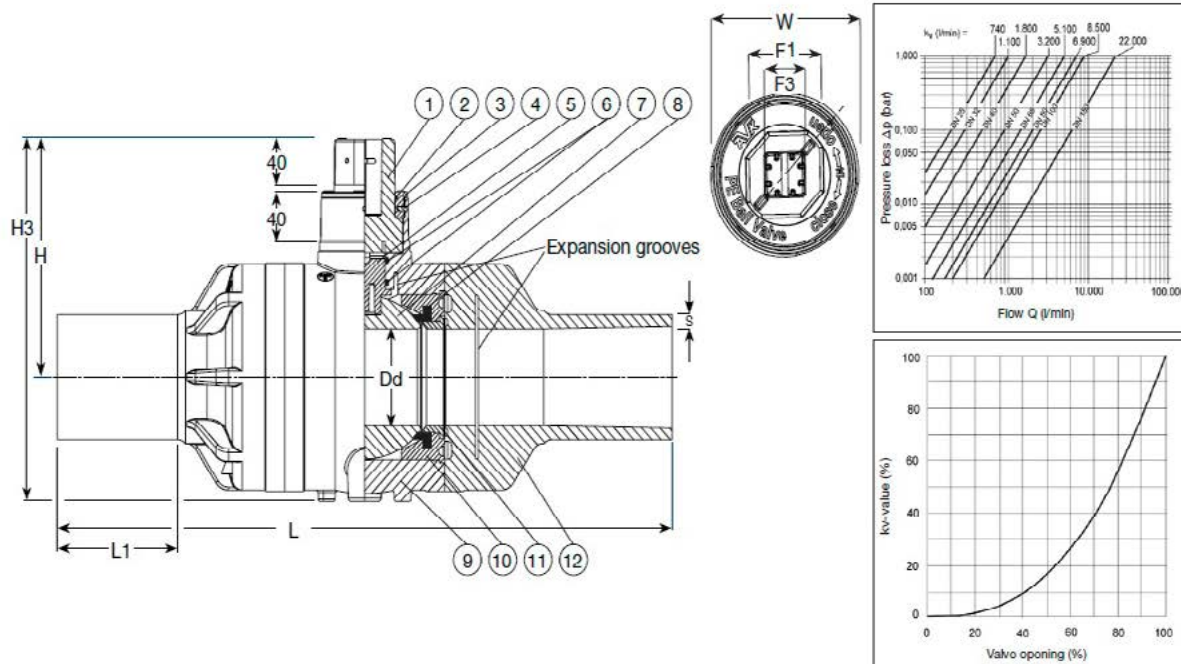

Component list

1. Connector	PA	7. Ball	PE100
2. O-ring	NBR rubber	8. Ball seat	NBR rubber
3. Bearing ring	PE 80	9. Body	PE100
4. Locking pin	PVC	10. Seat retainer	PE100
5. Stem	POM	11. Support ring	PE100
6. O-rings	NBR rubber	12. Spigot end	PE100

Components can be substituted with equivalent or higher class materials.

Reference nos. and dimensions

AVK ref. nos	DN/Ø mm	Dd mm	L mm	L1 mm	H mm	H3 mm	F1 mm	F3 mm	W mm	S mm	Torque Nm	Theoretical weight kg
85-020-50-200040	16 - 20	24	320	82	139	190	49,6	25,5	64	1,8	20	0.9
85-032-50-100040 (1)	25 - 32	24	322	76	139	190	49,6	25,5	64	3	20	1.0
85-040-50-100040 (1)	32 - 40	32	410	100	145	203	49,6	25,5	64	3,7	20	1.2
85-050-50-100040 (1)	40 - 50	40	415	100	152	217	49,6	25,5	64	4,6	30	1.6
85-063-50-100030	50 - 63	50	435	100	176	252	49,6	25,5	64	5,8	30	2.7
85-075-50-200030	65 - 75	64	515	105	182	267	49,6	25,5	85	6,9	35	3.9
85-090-50-200030	80 - 90	74	550	110	200	299	49,6	25,5	85	8,2	45	5.8
85-110-50-100030	100 - 110	86	595	115	210	320	49,6	25,5	85	10	60	8.0
85-125-50-000030	100 - 125	86	610	125	210	320	49,6	25,5	85	11,4	60	8.6
85-160-50-100030	150 - 160	120	690	120	254	403	49,6	25,5	115	14,6	80	19.6
85-180-50-000030	150 - 180	120	690	120	254	403	49,6	25,5	115	16,4	80	19.6

(1) With adaptor on safety connector