

# Helcor Cattle Underpass

## Economical Underpass Solution



Quick and easy to install — lightweight and durable

### Features

- Safe, convenient stock movement “across” the busiest roads.
- Cattle Underpasses eliminate traffic risk and reduce farmers’ unproductive hours.
- Helcor Underpasses save on materials and installation costs.
- Manufactured in accordance with NZS 4405:1986
- Helcor Underpasses are constructed from high quality, galvanized corrugated steel in diameters from 2550mm to 3600mm.
- Individual pipe sections are between 4 to 12m to suit the location.
- Lengths are jointed by a simple bolted band system.



### Installation

Design and installation of Helcor pipes is covered by NZS 4406:1986, which details the structural design and backfilling requirements. For pipes of these diameters a well-compacted backfill is required.

### Bedding

The ideal bedding is 250mm of compacted gravel and sand. Avoid bearing pipe on large rocks. Cover bedding with loose granular material to allow corrugations to fill.

### Backfilling

Ideal backfill is compacted gravel and sand. Unlike concrete pipes, the strength of the Helcor pipe comes largely from the force between the backfill and the pipe. Avoid clay, peat and soils with organic matter as backfilling materials. In difficult wet situations filter fabrics can be placed around backfill. This avoids the need for excessive evacuation or large amounts of imported backfill. Further advice can be obtained from Humes.



# Helcor Cattle Underpass

## Economical Underpass Solution

### Grade

A Helcor Underpass should be installed with a minimum 3% fall along its length to allow adequate drainage.

### Underpass Floor

The width of the concrete floor depends on depth of concrete laid. However, a minimum depth of 100mm of concrete, 1.75MPa at 28 days, combined with a minimum of one layer of welded mesh is recommended.

### Wall Protection

The interior surface of the pipe is epoxy painted to half height at the factory prior to the shipment. This reduces the risk of accelerated corrosion caused by livestock waste.

### Cover

Cover is the thickness of backfill over the top of pipe. Minimum cover recommended to withstand highway loading is 600mm.

#### Sizes Available

Diameters (mm)	Lengths	Minimum Cover (mm)
2550		
2700	individual pipe	
2850	lengths between	all 600mm
3000	4m-12m to suit	
3300	each location	
3600		

side elevation

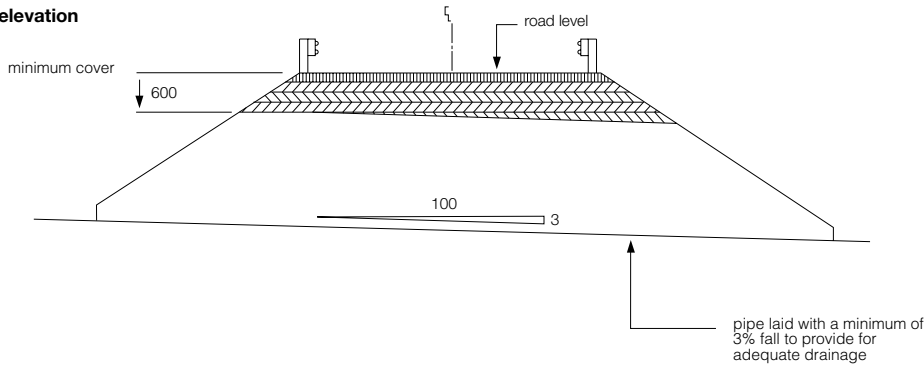

end elevation

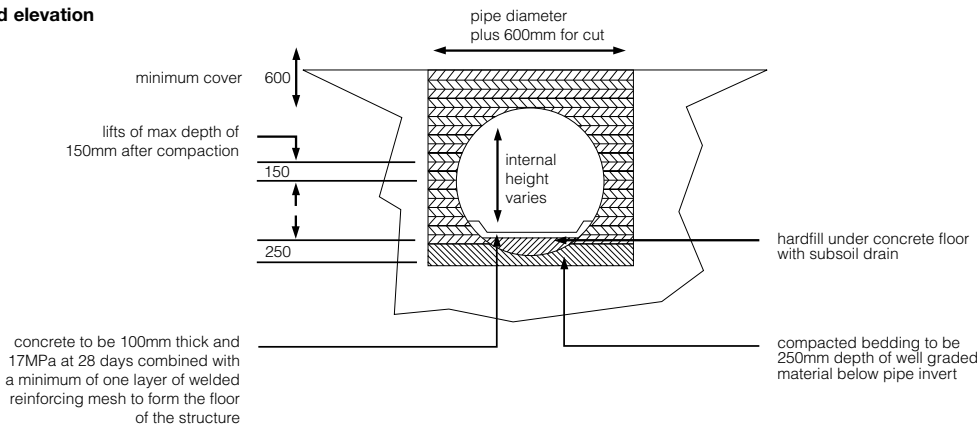

Disclaimer: "Buyers and users must make their own assessment of our products under their own conditions for their own use. All queries regarding product suitability or purpose or installation should be directed to the nearest Humes office for advice and assistance". Availability of product may differ slightly from that available in your area. © Copyright Humes Pipeline Systems 2004.

