

Trench shoring



Safe and efficient trenching

The trench shoring system actively supports the trench walls at all times and can be installed progressively with the excavation process.

Features

- Allows deep excavation with a very narrow trenching corridor
- Side plates move independently
- System may be used with multiple units in the ground

Benefits

- Provides total safety for workers
- Excavation can be undertaken adjacent to existing services and buildings
- Easy insertion and removal of side panels
- Keeps traffic lanes open where conventional trenching will not

How it works

Trench shoring system actively supports the trench walls at all times. Each strut is hinged and sprung where it connects to the side wall. This allows the side plates to move independently, making insertion and removal a breeze.

The shoring is supplied in modules 4.0 metres and 2.5 metres long by 2.2 metres high. The height can be extended by 1.3 metres with extension plates giving a total supporting height of 3.5 metres.

The width is adjustable also. The standard struts cater for trenches 1.0 metres to 1.3 metres wide. By adding the extension struts, trench widths can be extended out 3.3 metres.

Safety

The OSH 'Approved Code of Practice for Excavation and Shafts for Foundations' states that excavations over 1.5 metres deep must either:

- Have a trench wall battered back to a safe slope or,
- Have the stability of the trench walls certified by an engineer or,
- The trench walls must be shored with an approved system

Configurations

The system may be used with multiple units in the ground. The modules are then 'leap frogged' as the pipelaying and backfilling progresses.

We have a demonstration DVD available, just gives us a call on 0800 502 112.





Installation

Delivery



Assembly



Installation



The Trenchshore Safe Operating Procedures Manual will be provided with your order. Contact your local Humes Sales Centre or Sales Representative for more information.

Shoring configurations & weights

Shoring modules (Length x height)	Trench width*	Assembly weights (kg)
Base units 4.0m x 2.2m	1.0m - 1.3m	2153
	1.5m - 1.8m	2234
	2.0m - 2.3m	2316
	2.5m - 2.8m	2360
	3.0m - 3.3m	2404
Extension units 4.0m x 1.3m	1.0m - 1.3m	1285
	1.5m - 1.8m	1325
	2.0m - 2.3m	1366
	2.5m - 2.8m	1388
	3.0m - 3.3m	1410
Base units 2.5m x 2.2m	1.0m - 1.3m	1663
	1.5m - 1.8m	1744
	2.0m - 2.3m	1826
	2.5m - 2.8m	1870
	3.0m - 3.3m	1914
Extension units 2.5m x 1.3m	1.0m - 1.3m	1045
	1.5m - 1.8m	1085
	2.0m - 2.3m	1126
	2.5m - 2.8m	1148
	3.0m - 3.3m	1170

* Note: Trench width refers to the working width between the inside faces of the panels. Panels are 105mm thick – add 210mm to obtain overall width.

KS100

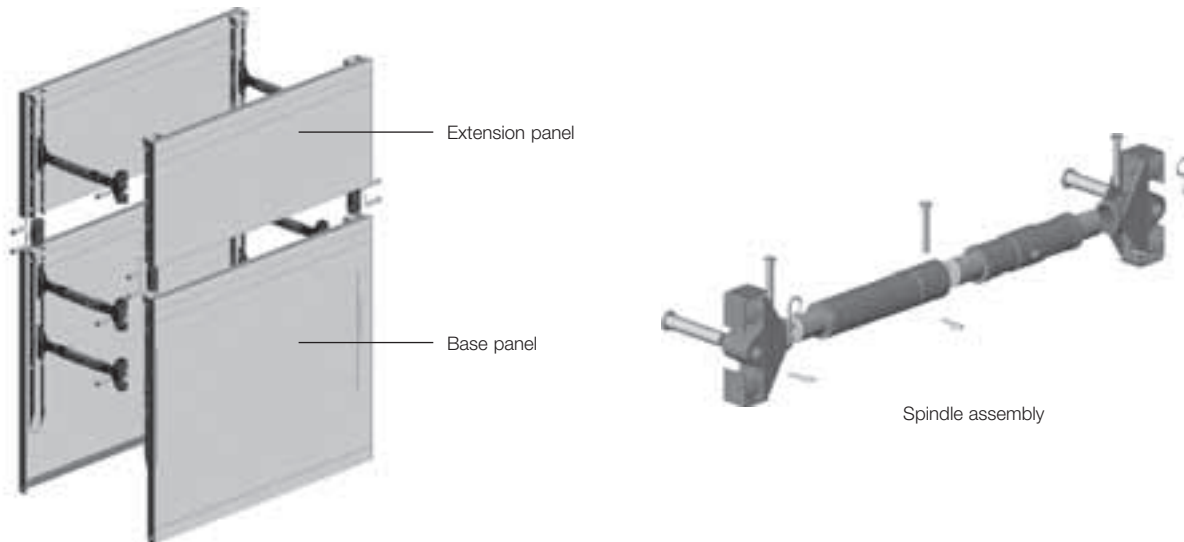

Buyers and users of the products described in this brochure must make their own assessment of the suitability and appropriateness of the products for their particular use and the conditions in which they will be used. All queries regarding product suitability, purpose or installation should be directed to the nearest Humes Sales Centre for service and assistance. © Fletcher Concrete and Infrastructure Limited 2007. Printed 10/07.

