

Tees and hydrant tees



This comprehensive range of fittings are designed to meet the requirements of the joint AS/NZS 2280 standard. This standard ensures that all pipe fittings have consistent dimensions and manufacturing tolerances, and are fully interchangeable with other AS/NZS 2280 fittings.

End Features

Humes Equal, Unequal and Hydrant Tees have flanges drilled standard or with special drillings as required. Spigot ends are manufactured in accordance with AS/NZS 2280 and are consistent with all AS/NZS 2280 fittings.

Features

- Complies to AS/NZS 2280 Standard
- High strength light weight ductile iron construction
- Compatible with all current pipe types

Options

- Multiple end configurations
- 165mm PCD hydrant drilling



Tees and hydrant tees

Tee Scour (Socket/Socket/Flange)

Description

DualSeal Ductile Iron equal & unequal tees

Use

For use with potable & non-potable water or waste

Manufacturing Standard

Manufactured to AS/NZS 2280

Coating

Coated to AS/NZS 4158

Dimensions

Nominal Size mm	PN 35 (a)	PN 35 (a1)	(h)	(L)	
(DN)	(dn)	mm	mm	mm	
150	80	9	8	225	210
200	80	10	8	250	210
225	100	10	8	265	240
250	100	10	8	280	240

Nominal Size mm	PN 35 (a)	PN 35 (a1)	(h)	(L)	
(DN)	(dn)	mm	mm	mm	
300	100	11	8	310	240
375	150	12	9	375	310
450	150	13	9	415	310
500	150	14	9	440	310

Nominal Size mm	PN 35 (a)	PN 35 (a1)	(h)	(L)	
(DN)	(dn)	mm	mm	mm	
600	150	15	9	495	310
750	200	18	10	575	370

Notes

- Minimum wall thickness for other pressure classifications shall comply with AS/NZS 2280:2004 – Clause 1.6.3.
- For details of flanges, see AS 4087
- For details of dimension 'f' and socket profile, refer to manufacturer.
- Sockets can be replaced by flanges

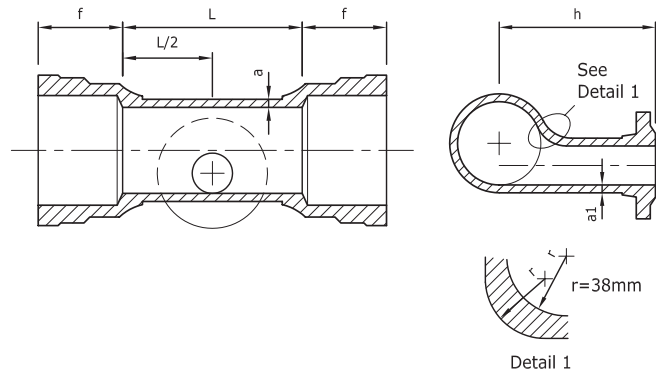

Tee (Socket/Socket/Socket)

Description

DualSeal Ductile Iron equal & unequal tees

Use

For use with potable & non-potable water or waste

Manufacturing Standard

Manufactured to AS/NZS 2280

Coating

Coated to AS/NZS 4158

Dimensions

Nominal Size mm	PN 35 (a)	PN 35 (a1)	(h)	(L)	(r)	
(DN)	(dn)	mm	mm	mm	mm	
100	100	8	8	115	230	38
150	100	9	8	145	230	38
150	150	9	9	145	290	38
200	100	10	8	170	230	38
200	150	10	9	170	290	38
200	200	10	10	170	340	38
225	100	10	8	185	240	38
225	150	10	9	185	300	38
225	200	10	10	185	350	38
225	225	10	10	190	380	38
250	100	10	8	200	240	38
250	150	10	9	200	300	38
250	200	10	10	200	350	38
250	225	10	10	205	380	38
250	250	10	10	205	410	38

Nominal Size mm	PN 35 (a)	PN 35 (a1)	(h)	(L)	(r)	
(DN)	(dn)	mm	mm	mm	mm	
300	100	11	8	230	240	38
300	150	11	9	230	300	38
S300	200	11	10	230	350	38
S300	225	11	10	235	380	38
S300	250	11	10	235	410	38
S300	300	11	11	245	490	51
375	200	12	10	270	360	38
375	225	12	10	275	390	38
S375	250	12	10	275	420	38
S375	300	12	11	285	500	51
S375	375	12	12	305	610	64
450	250	13	10	315	420	38
S450	300	13	11	325	500	51
S450	375	13	12	345	610	64
S450	450	13	13	345	690	64

Nominal Size mm	PN 35 (a)	PN 35 (a1)	(h)	(L)	(r)	
(DN)	(dn)	mm	mm	mm	mm	
500	250	14	10	340	420	38
500	300	14	11	355	500	51
S500	375	14	12	370	610	64
S500	450	14	13	370	690	64
S500	500	14	14	385	770	76
600	375	15	12	425	610	64
S600	450	15	13	425	690	64
S600	500	15	14	435	770	76
S600	600	15	15	435	870	76
750	300	18	11	485	510	51
750	375	18	12	505	620	64
750	450	18	13	505	700	64
S750	500	18	14	515	780	76
S750	600	18	15	515	880	76
S750	750	18	18	535	1070	90

Notes

- Minimum wall thickness for other pressure classifications shall comply with AS/NZS 2280.
- For details of dimension f and socket profile, refer to manufacturer.

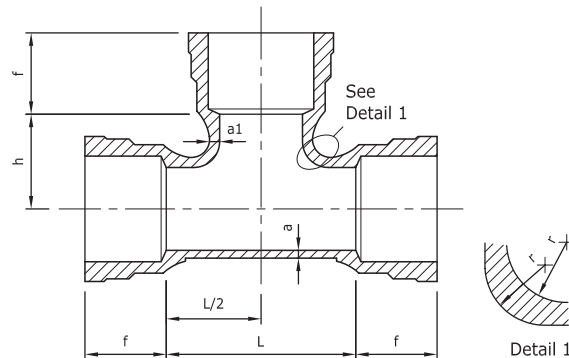

Tees and hydrant tees



Tee (Socket/Socket/Flange)

Description

DualSeal Ductile Iron equal & unequal tees

Use

For use with potable & non-potable water or waste

Manufacturing Standard

Manufactured to AS/NZS 2280

Coating

Coated to AS/NZS 4158

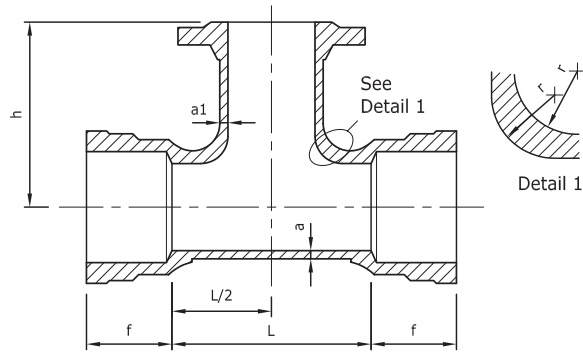

Dimensions

Nominal Size mm		PN 35 (a)	PN 35 (a1)	(h)	(L)	(r)
(DN)	(dn)	mm	mm	mm	mm	mm
100	80	8	8	195	210	38
100	100	8	8	195	230	38
150	80	9	8	225	210	38
150	100	9	8	225	230	38
150	150	9	9	250	290	38
200	80	10	8	250	210	38
200	100	10	8	250	230	38
200	150	10	9	275	290	38
200	200	10	10	275	340	38
225	80	10	8	265	220	38
225	100	10	8	265	240	38
225	150	10	9	290	300	38
225	200	10	10	290	350	38
225	225	10	10	305	380	38
250	80	10	8	280	220	38
250	100	10	8	280	240	38
250	150	10	9	305	300	38
250	200	10	10	305	350	38
250	225	10	10	320	380	38
250	250	10	10	320	410	38
300	80	11	8	310	220	38
300	100	11	8	310	240	38
300	150	11	9	335	300	38
300	200	11	10	335	350	38
S300	225	11	10	350	380	38
S300	250	11	10	350	410	38
S300	300	11	11	375	490	51
375	80	12	8	350	230	38
375	100	12	8	350	250	38
375	200	12	10	375	360	38
375	225	12	10	390	390	38
375	250	12	10	390	420	38

Nominal Size mm		PN 35 (a)	PN 35 (a1)	(h)	(L)	(r)
(DN)	(dn)	mm	mm	mm	mm	mm
S375	300	12	11	415	500	51
S375	375	12	12	415	610	64
450	80	13	8	390	230	38
450	100	13	8	390	250	38
450	250	13	10	430	420	38
S450	300	13	11	455	500	51
S450	375	13	12	485	610	64
S450	450	13	13	495	690	64
500	80	14	8	415	230	38
500	100	14	8	415	250	38
500	250	14	10	455	420	38
500	300	14	11	485	500	51
S500	375	14	12	510	610	64
S500	450	14	13	520	690	64
S500	500	14	14	550	770	76
600	80	15	8	470	230	38
600	100	15	8	470	250	38
600	300	15	11	535	500	51
600	375	15	12	565	610	64
S600	450	15	13	575	690	64
S600	500	15	14	600	770	76
S600	525	15	14	600	790	76
S600	600	15	15	615	870	76
750	100	18	8	550	260	38
750	300	18	11	615	510	51
750	375	18	12	645	620	64
750	450	18	13	655	700	64
S750	500	18	14	680	780	76
S750	525	18	14	680	800	76
S750	600	18	15	695	880	76
S750	675	18	16	695	960	76
S750	750	18	18	725	1070	90

Notes

1. Minimum wall thickness for other pressure classifications shall comply with AS/NZS 2280.
2. For details of dimension f and socket profile, refer to manufacturer.
3. For details of flanges refer AS4087

Tees and hydrant tees



Tee (Flange/Flange/Flange)

Description

DualSeal Ductile Iron equal & unequal tees

Use

For use with potable & non-potable water or waste

Manufacturing Standard

Manufactured to AS/NZS 2280

Coating

Coated to AS/NZS 4158

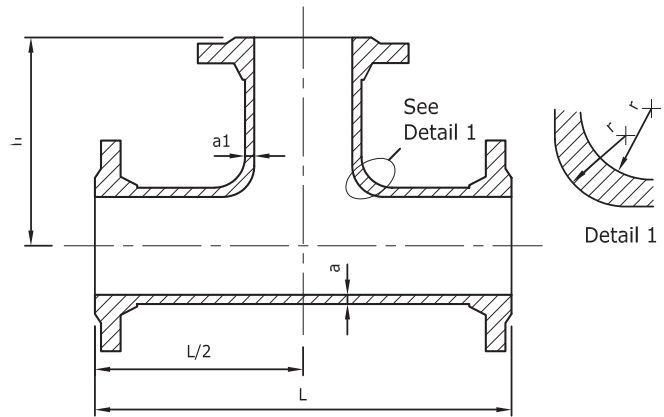

Dimensions

Nominal Size mm		PN 35 (a)	PN 35 (a1)	(h)	(L)	(r)
(DN)	(dn)	mm	mm	mm	mm	mm
100	100	8	8	178	356	38
150	100	9	8	203	406	38
150	150	9	9	203	406	38
200	100	10	8	241	484	38
200	150	10	9	241	484	38
200	200	10	10	241	484	38
225	100	10	8	254	508	38
225	150	10	9	254	508	38
225	200	10	10	254	508	38
225	225	10	10	254	508	38
250	100	10	8	267	534	38
250	150	10	9	267	534	38
250	200	10	10	267	534	38
250	225	10	10	267	534	38
250	250	10	10	267	534	38
300	100	11	8	305	610	38
300	150	11	9	305	610	38
S 300	200	11	10	305	610	38
S 300	225	11	10	305	610	38
S 300	250	11	10	305	610	38
S 300	300	11	11	305	610	51
375	200	12	10	356	738	38
375	225	12	10	356	738	38
S 375	250	12	10	356	738	38
S 375	300	12	11	356	738	51
S 375	375	12	12	368	738	64

Nominal Size mm		PN 35 (a)	PN 35 (a1)	(h)	(L)	(r)
(DN)	(dn)	mm	mm	mm	mm	mm
450	250	13	10	394	814	38
S 450	300	13	11	394	814	51
S 450	375	13	12	406	814	64
S 450	450	13	13	406	814	64
500	250	14	10	432	890	38
500	300	14	11	432	890	51
S 500	375	14	12	444	890	64
S 500	450	14	13	444	890	64
S 500	500	14	14	444	890	76
525	250	14	10	444	914	38
525	300	14	11	444	914	51
S 525	375	14	12	457	914	64
S 525	450	14	13	457	914	64
S 525	500	14	14	457	914	76
600	300	15	11	483	1016	51
600	375	15	12	495	1016	64
S 600	450	15	13	495	1016	64
S 600	500	15	14	495	1016	76
S 600	525	15	14	495	1016	76
750	300	18	11	615	890	51
750	375	18	12	645	1000	64
750	450	18	13	655	1080	64
S 750	500	18	14	680	1160	76
S 750	525	18	14	680	1180	76
S 750	600	18	15	695	1260	76
S 750	750	18	18	725	1450	90

Notes

1. Minimum wall thickness for other pressure classifications shall comply with AS/NZS 2280.
2. For details of flanges refer AS4087

Buyers and users of the products described in this brochure must make their own assessment of the suitability and appropriateness of the products for their particular use and the conditions in which they will be used. All queries regarding product suitability, purpose or installation should be directed to the nearest Humes Sales Centre for service and assistance. © Fletcher Concrete and Infrastructure Limited 2007. Printed 03/07.



Freephone 0800 502 112

www.humes.co.nz