

# Concrete Septic Tanks 2700, 3300 & 4000 litre sizes



## Durable concrete septic tanks

As market leaders Humes Pipeline Systems offers a range of durable septic tanks designed to provide on-site primary treatment for residential and holiday home wastewater.

### Features

- Precast concrete
- Anti-floatation foot at base of tank
- Range of sizes (2700 litre - 4000 litre)
- Optional partition wall with gas baffle
- Optional tube filter

### Benefits

- Efficient separation of solids for a range of applications
- Cost effective
- The optional tube filter and gas baffle reduces solids from being carried over to disposal field
- Easy to maintain



# Concrete Septic Tanks 2700, 3300 & 4000 litre sizes



## 2700 litre septic tank

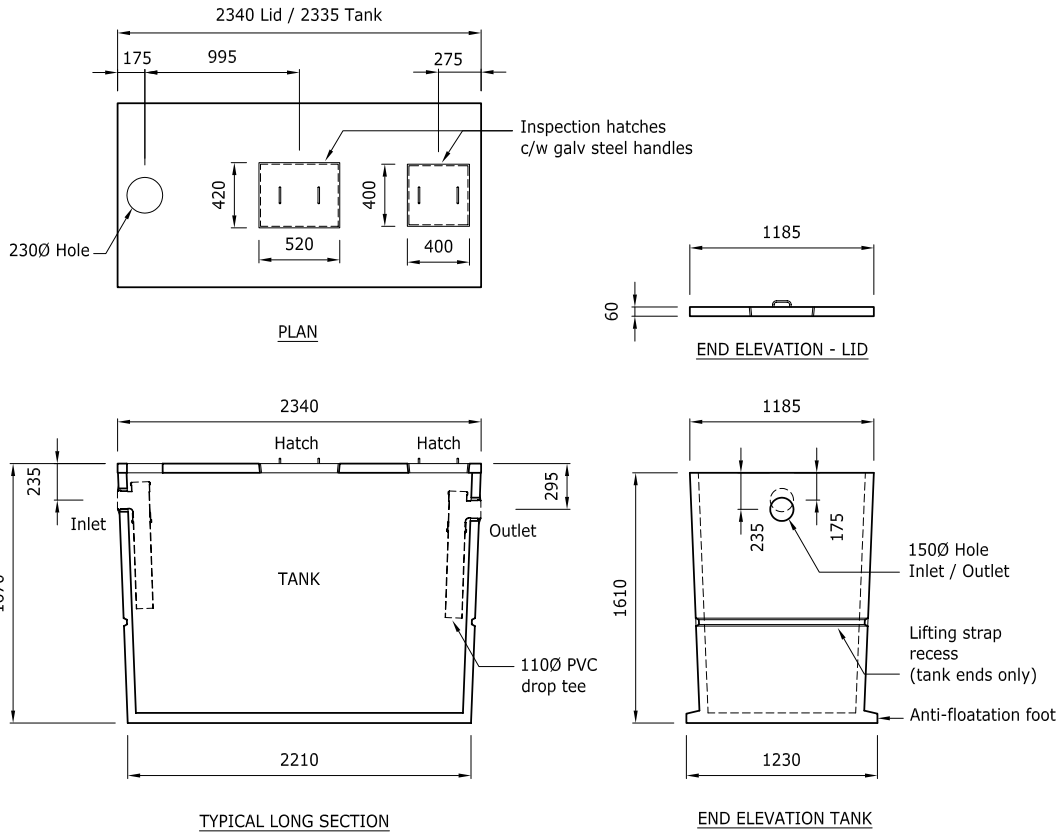

## 3300 litre septic tank

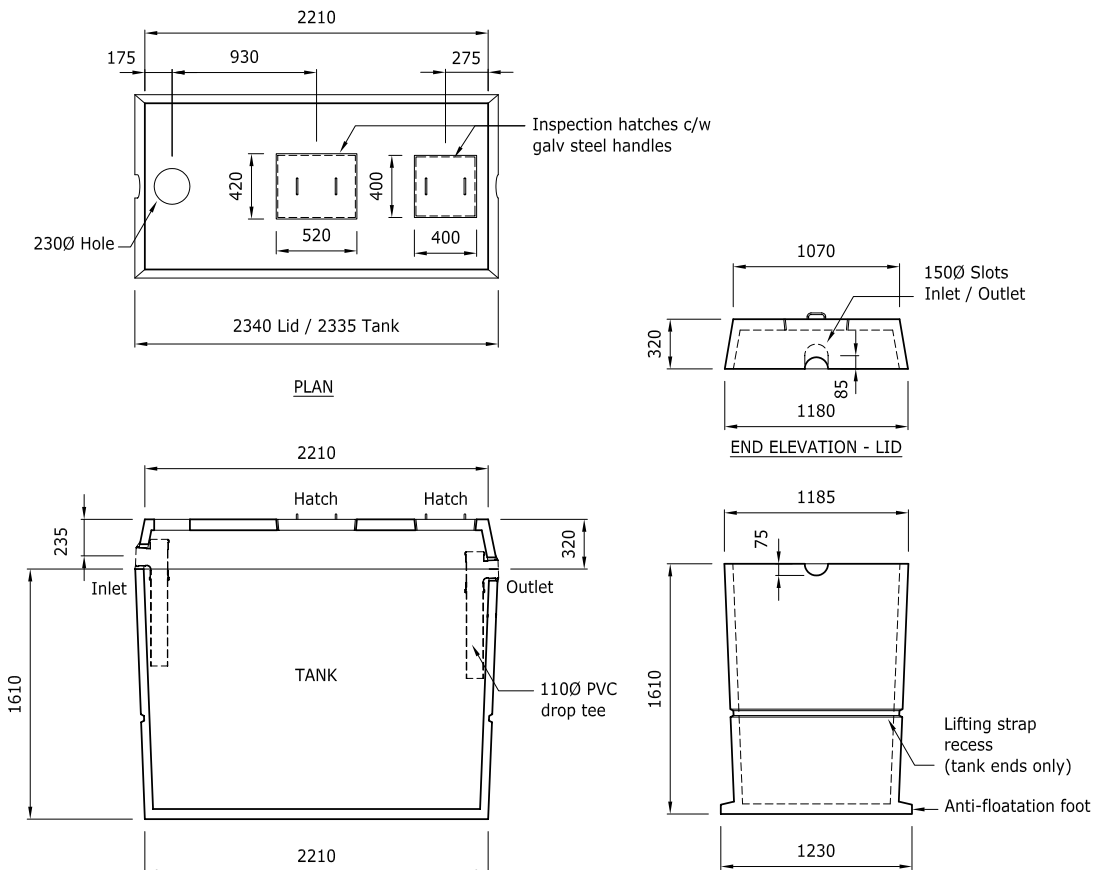

# Concrete Septic Tanks 2700, 3300 & 4000 litre sizes



## 4000 litre septic tank

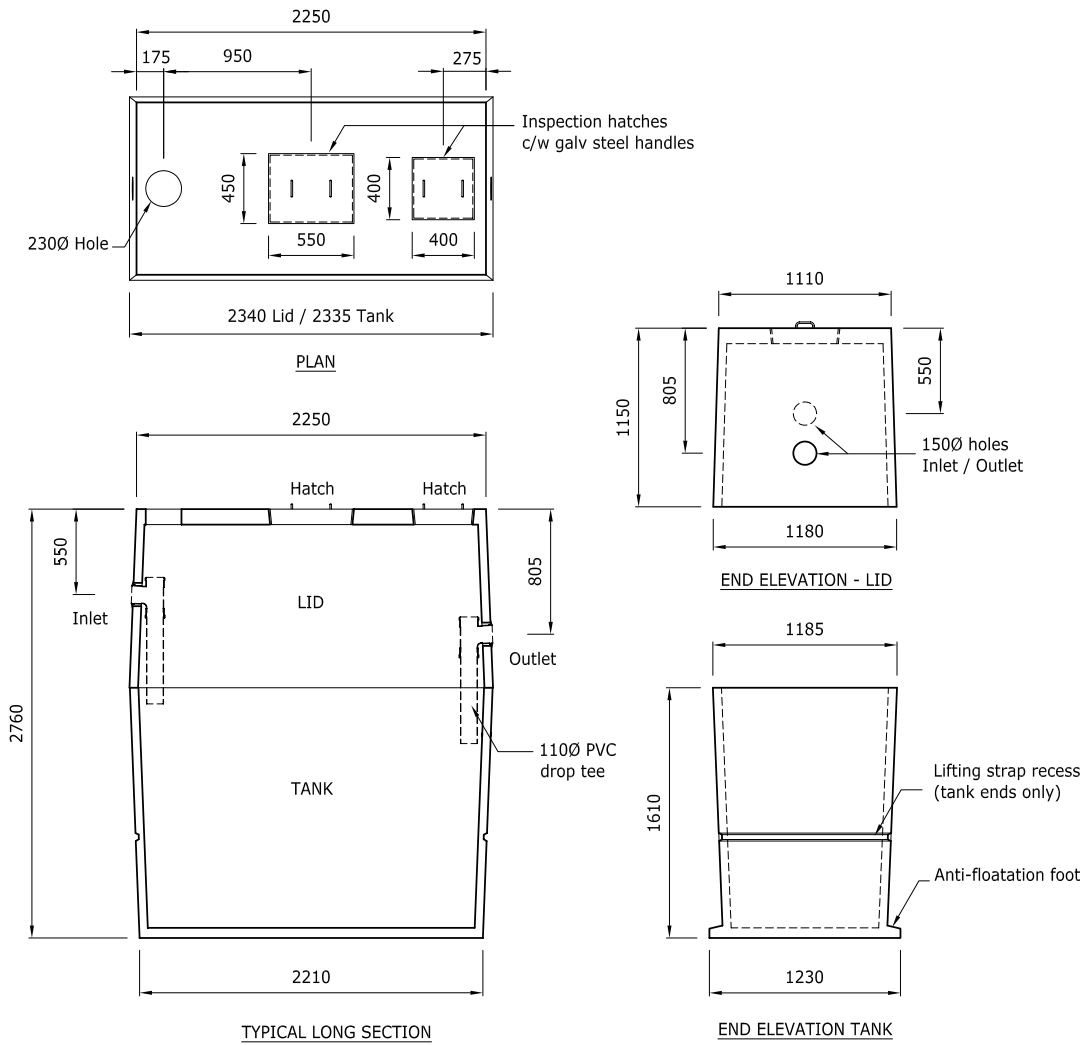

## Tank mass (kgs)

Litres	Tank	Lid	Total
2700	1875	700	2575
3300	1875	825	2700
4000	1875	1650	3525



## What does a septic tank do?

The septic tank receives the household wastewater flows and separates the contents into solids, liquids and scum.

The solids are digested by anaerobic bacteria breaking down approximately 40% of the solid matter into sludge. Sufficient storage is provided to permit satisfactory primary treatment for approximately 3 years.

The liquids are discharged into the on-site disposal field where further treatment takes place.

## Installation

The tank must be level when installed to maintain the correct height difference between the inlet and outlet.

The septic tank should be located to allow for easy pumping out of sludge. No part of the system should be subject to heavy traffic.

Compliance with regulations should be checked with the relevant local authority. The septic tank system should be installed by a registered installer approved by the council.



**Humes 3300 Litre Septic Tank**

## Septic tank care

The average household will need to have its septic tank pumped out about every three years. A good indication is when the sludge level approaches the one-third full mark. If more than this amount builds up, the sludge may get into the disposal field and clog the system. The use of outlet effluent filters can avoid this problem and improve overall performance. To ensure regular service, a maintenance record of the system should be kept.

The septic tank system should not be treated as a general disposal unit. Some substances will not degrade fast enough, while others are harmful to the bacteria that break down the solids.

Grease must be prevented from entering the system. Coffee grounds, bones, cooking fats, cigarette filter butts, disposable nappies, paper towels and the like should also be avoided. Toilet paper causes no problems as it decomposes quicker than most materials. Bleaches, cleaners and other household products will not harm the system if used in moderation.

The system will become overloaded if excessive stormwater is allowed to enter. This must be channelled into a separate system.

Humes Pipeline Systems recommends you install a Humes Grease Trap which is a settling system designed to trap grease and suspended sediments prior to entering your septic tank. For more information on the Humes Grease Trap please refer to our Grease Trap brochure available online or at your local Humes Sales Centre.