

Pump Station Specifications

Model No	Normal Capacity (lts)	Depth (mm)	Diameter (mm)
PSPE-900	900	1550	1000
PSPE-1200	1200	1950	1000
PSPE-1500	1500	2250	1000
PSPE-1800	1800	2650	1000

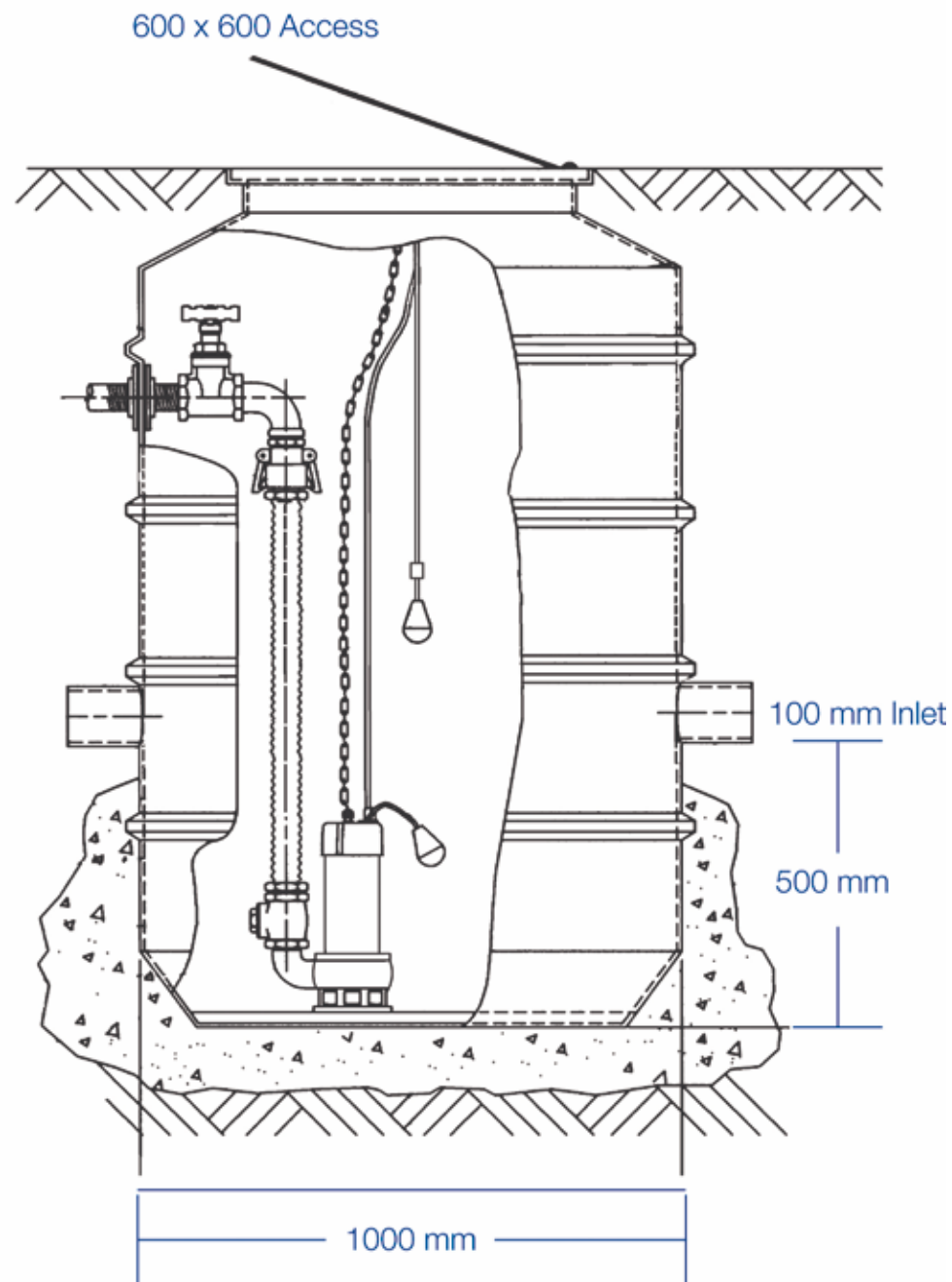

 **PUMP & VALVE** 
SPECIALTIES

New!

Packaged Pump Stations

- Residential
- Commercial
- Easy to install
- Granny Flats
- Competitive
- Guaranteed

Pre-assembled units include pump, chamber, control panel and cable assemblies.

**PUMP
&
VALVE**
SPECIALTIES LTD



Fluid-Tec Packaged Pump Stations

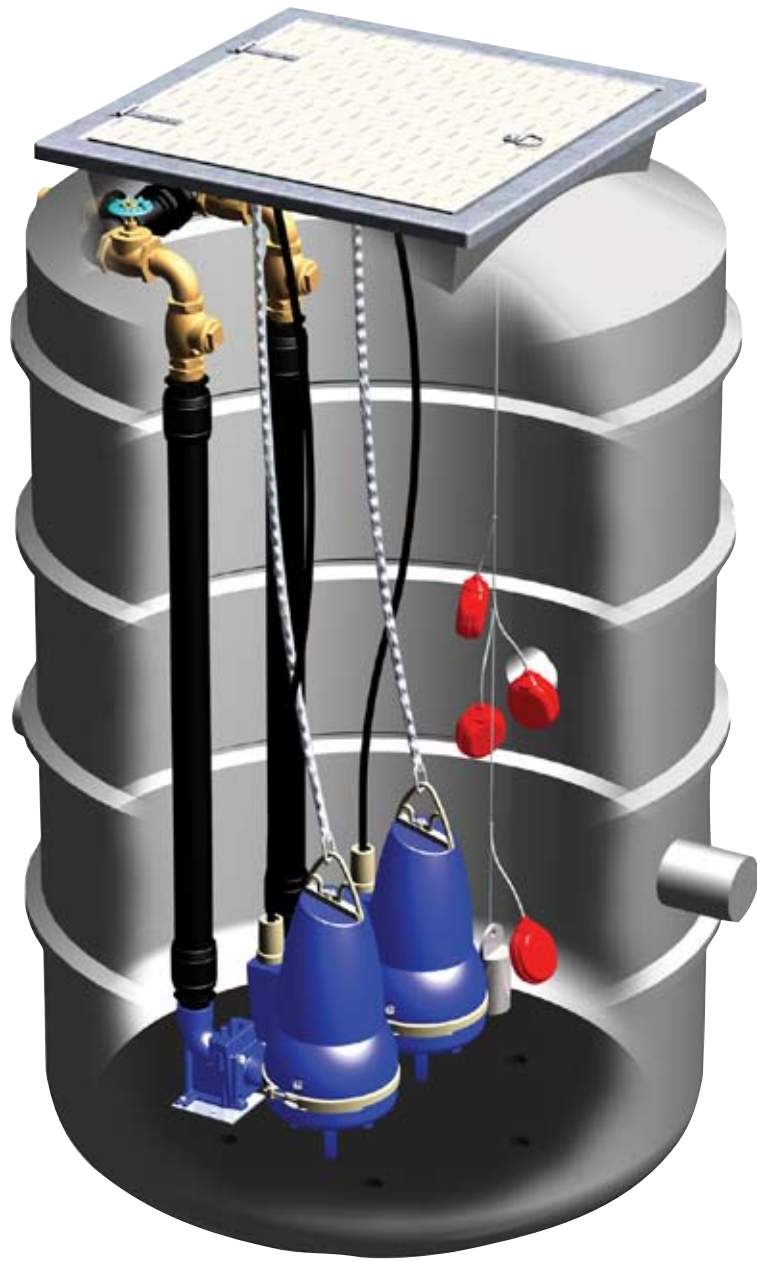

Packaged pump station pricing examples

900 litre

1.0m diameter x 1.59m deep complete with a 600 x 600 trafficable steel lid and all pipework fully fitted in the chamber

Option 1 (single pump)
Maximum of 7m total head
Quality single phase vortex pump
\$3,087.51 plus GST

1200 litre

1.0m diameter x 1.89m deep complete with a 600 x 600 trafficable steel lid and all pipework fully fitted in the chamber

Option 1 (single pump)
Maximum of 7m total head
Quality single phase vortex pump
\$3,439.10 plus GST

Do you require a pump station for your next project?

Pump & Valve Specialties supply packaged pump stations to the trade for domestic and industrial situations where conventional gravity is not possible.

- **Steel trafficable lid**
- **High Quality On/Off Ball valve(s)**
- **High Quality Ball Check valve(s)**
- **High Strength Schedule 80 PVC pipework**
- **Control Panel including audible and visual alarms, pump duty alternation, control breakers for each pump and main isolation switch. (Not shown).**
- **Start/Stop/Alarm Level controls**
- **Strong Durable Polyethylene chamber**
- **Four pre-moulded inlet stubs ready for connection to gravity line**
- **Submersible pump(s) sized to meet your duty point**
- **Smooth interior wall – this won't corrode away and leave a pitted surface**

Advantages of Fluid-Tec Polyethylene packaged pump stations over concrete pump stations:

- **Lighter** – Much easier to transport and install.
- **Smooth interior surface** – Easier to clean down as part of the maintenance schedule.
- **Comprehensive package** – Pump & Valve offer a 'One Stop Shop' service including the chamber, all pipework, level controls, pump controller and a lid arrangement.
- **Factory built** – All the components are fitted out in the factory which means the highest level of quality is achieved. This also eliminates any problems arising from the components being 'fitted out' onsite by different tradesmen.
- **No hidden costs** – As we supply a complete package, there are no hidden costs that you will discover after purchasing a Fluid-Tec packaged pump station
- **Plug & Play system** – Pump & Valve supply most pumps with IP68 rated plugs on the pump and float cables. This eliminates problems related to faulty waterproof electrical joints made in the chamber. This also means an electrician does not have to disconnect the pump if it needs to be removed from the pit.

These are only a few of the great advantages we offer.

We look forward to hearing from you soon.

Best regards,

The Pump & Valve Team

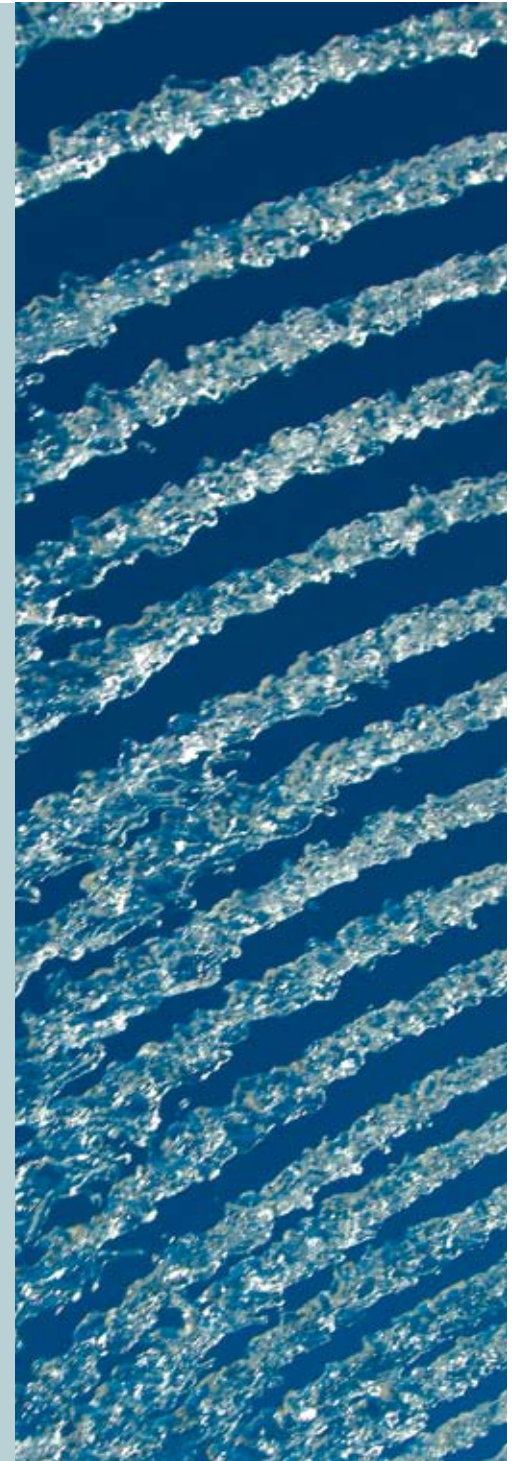

For help on sizing and pricing for a Fluid-Tec packaged pump station fill in the blanks below and fax to (09) 270 4905.

Difference in ground levels between the pump station and the discharge manhole m

Length of the pump rising main m

Number of bedrooms in dwelling m

Project name/Location

Contact Details