

Humes Max Pit maximum quantity catchpit

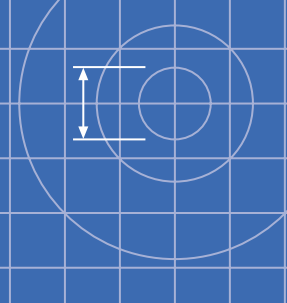

Designed to capture up to 95% of a 50 litre per second flow

The Humes Max Pit has been developed to capture the “Maximum Quantity” of stormwater flow with the most economic efficiency. Suitable for HN-HO-72 loadings, the catchpit and grate unit still maintains its aesthetic appeal. Safety has been designed into the units with children, bicycles and pedestrians in mind.

Testing and Design

Testing of the Manning Grate was carried out on a full size test rig at the University of South Australia, providing a full comprehensive set of design data. At the request of the Auckland City Council, inlet surrounds and pit designs were carried out to optimise the performance of both grate and pit.

Applications

- High flow areas
- Roadways
- Motorways
- Tight horizontal and vertical curvatures
- Narrow property frontages

Features

- Hydraulically efficient
- Full size testing completed
- Standard drawings available
- Complies with AS 3996
- Aesthetically fits with standard kerb
- Comprehensive design charts

Benefits

- Improved stormwater capture
- Pedestrian friendly
- Bicycle safe
- Theft resistant



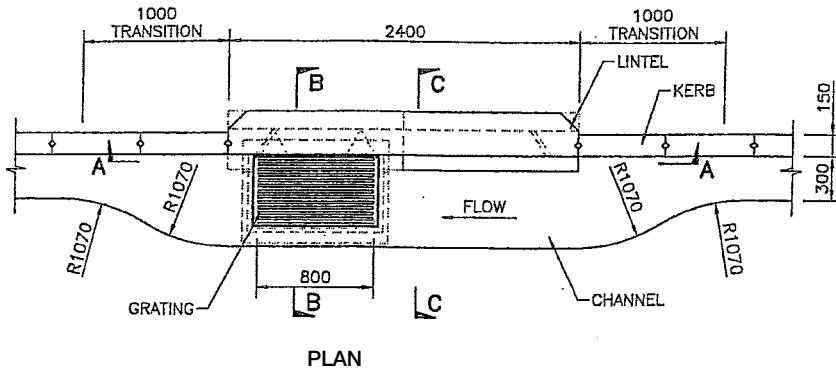

PLAN

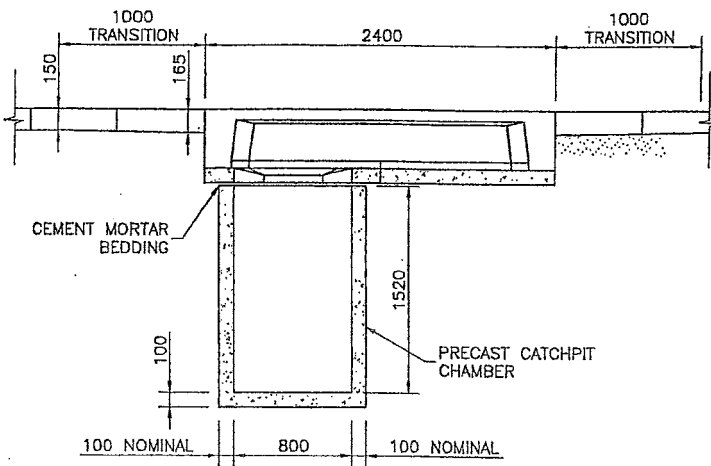

SECTION A-A

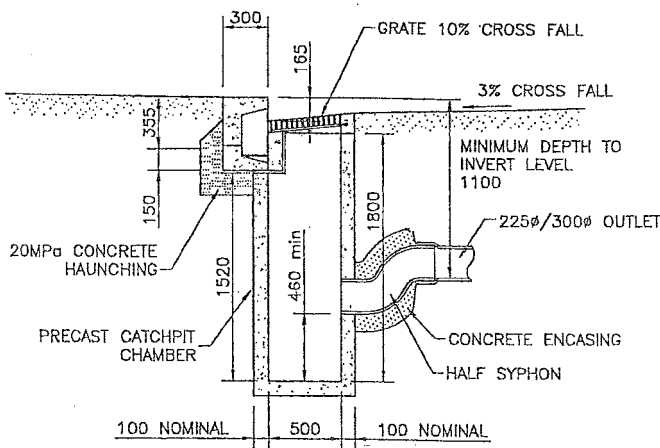

SECTION B-B

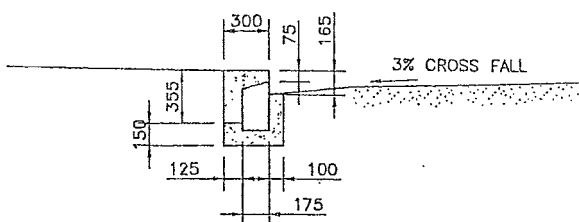

SECTION C-C

Notes

1. Concrete to be 25 MPa
2. Catchpits to be 1.8m deep
3. Half syphon to be used in all cases
4. Grates shall be Max Q 800 x 500
5. Transition - Kerb height changes from 150 to 165
6. Capacity of 225ø syphon outlet - limit to 50 L/S
7. Precast units A and B with lintel can be retrofitted to existing catchpit

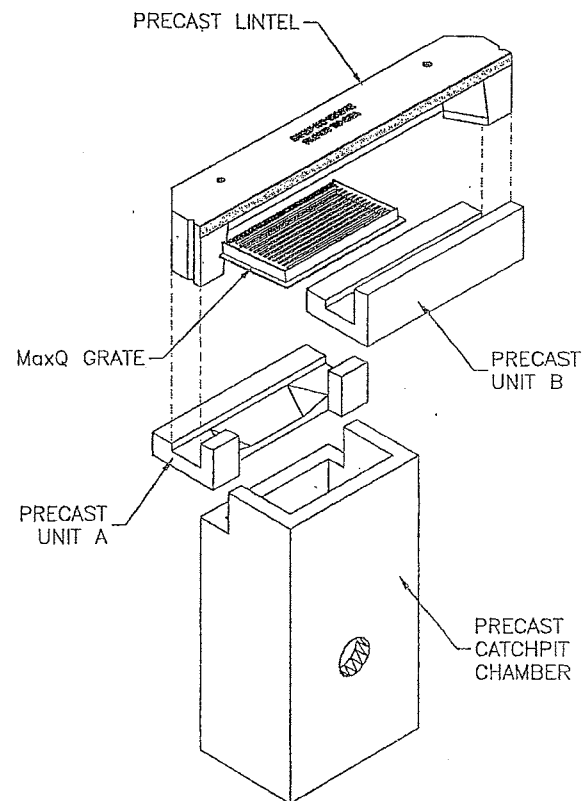
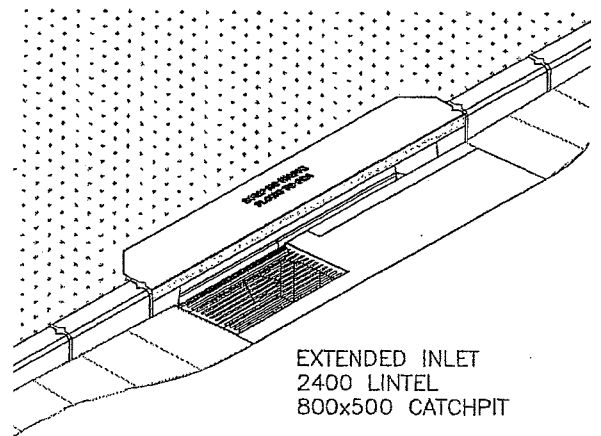

NOTE: When retrofitting unit A to existing catchpit, trim back existing catchpit as above. Place unit A centrally over back of catchpit on concrete bedding.

maximum quantity catchpit

Gutter Flow Design and Capture Charts

The following Charts have been sourced from the Queensland Urban Drainage Manual and Max Q. The charts are used to check the maximum spacing of the catchpits and the flow captured.

Gutter Flow as a Function of Road Slope S

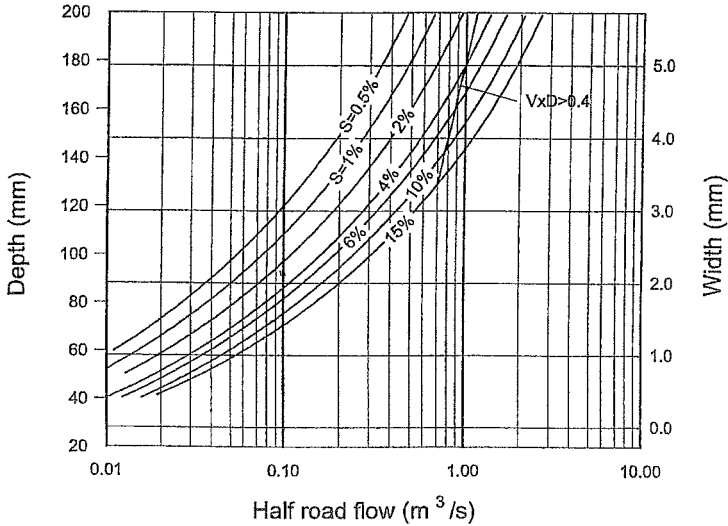

Design Chart 1 – Kerb and Gutter Flow Velocity using Izzard's Equation Source: QUDM (1992)

Based on 3% road crossfall
 Barrier kerb type 1 (450 mm)
 $n_p = 0.015$
 $n_g = 0.013$

Allowable Widths of Flow

The allowable gutter flow widths have been set to collect run-off from a carriage way that provides for safe passage of traffic and pedestrians during the design run-off events. The allowable gutter flow widths are set out in the table below:

Criteria	Design Limit
Arterial Route	1.5 m
Sag Point	2.0 m
Local Streets	2.0 m
Pedestrian crossing, bus stops, etc	0.45 m

Catchpit Blockage Allowance

As a general guide, the following design blockages shall be considered:

- Catchpits on slopes – 10% (ie. Multiply by a factor of 0.9 for system design)
- Catchpits in sags – 0% (inlet capacity curves based on grating being totally blocked, therefore no allowance required)

Inlet Capacity – Inlets on Grade

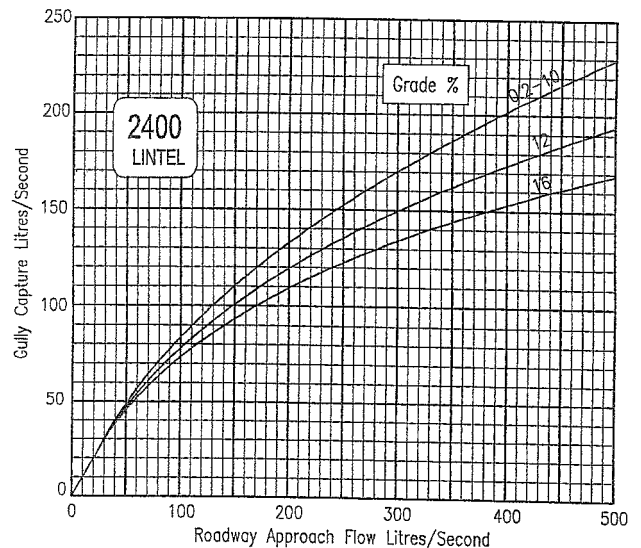
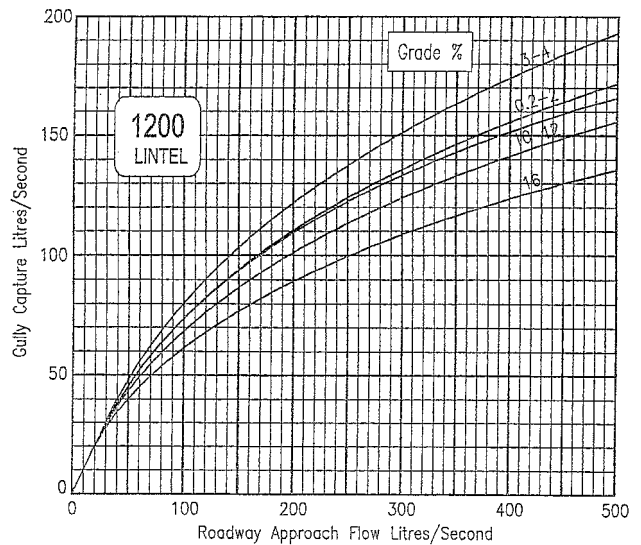

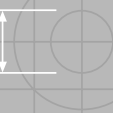

Inlet Capacity - Inlets in Sags

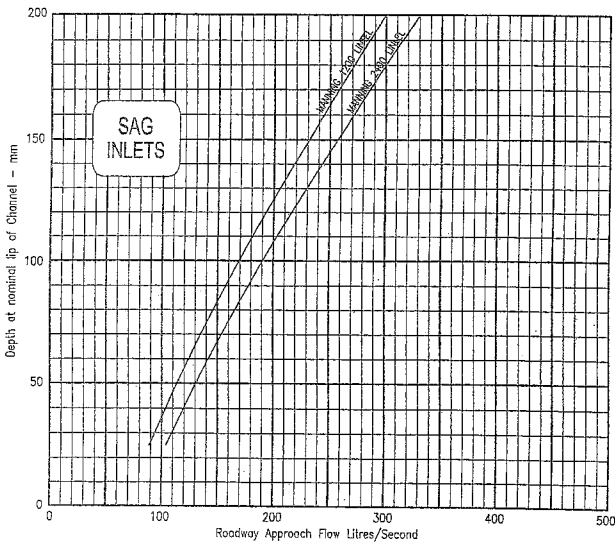

Worked Example on Catchpit Spacing

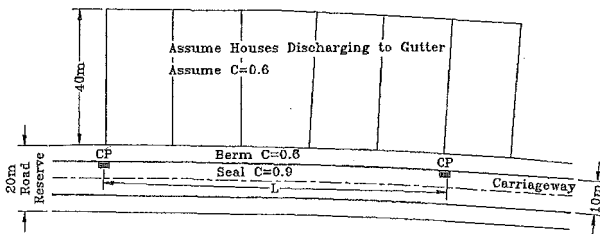

Assume gutter with uniform longitudinal slope of 2%.

Problem – determine maximum permissible catchpit spacing

Assume – time of concentration 10 minutes
 – rainfall intensity 96 mm/hr
 – storm return period 1 in 10 years
 – no bypass flow at CP uphill

CA = $(0.6 \times 40 \times L) + (0.9 \times 5 \times L) + (0.8 \times 5 \times L)$
 = 32.5 L m²
 = 32.5 L x 10⁻⁴ hectares

Q = 2.75 CIA
 = 2.75 x 96 x 32.5 L x 10⁻⁴
 = 0.8580 L litres/sec

Using Design Chart 1 (Kerb and Gutter Flow).
 The limiting gutter flow based on flow not exceeding 2.0m in width.

(Refer Table 1)

Therefore allowable flow = 0.075 m³/sec
 = 75l/sec

Therefore maximum spacing L = $\frac{75}{0.8580}$
 = 87.4 < 95m
 ok for residential area

Check inlet capture for a catchpit on a slope of 2% with a 2.4m lintel.

Design chart 2

From: Road approach flow – 75 L/S
 Capture – 69 L/S
 Less 10% for blockage – 69 x 0.1 = 6.9
 Capture – 62 l/sec
 Therefore bypass flow – 12.9 L/S

Capture greater than 50 L/S therefore 300 dia. syphon outlet required. (See notes on drawing 12908/213-1)

Note: bypass flow to be added to run off flow at next catchpit.

Installation

Humes Max Pit catchpit componentry are supplied complete with cast iron frames and grates. Soft spots have been designed for easily adjustable heights for the outlet pipe.

Maintenance

There is no blanket rule for maintaining catchpits as each application will have different conditions and each governing authority will have differing expectations. It should be noted that catchpits are not designed to be stormwater treatment devices.

Manufacturing Standards

Precast manufacture is to NZS 3109:1997 with surface finishes to NZS 3114:1987, F4 and U2 for formed and trowelled respectively.

For further details please contact your local Humes Sales Representative.

Disclaimer: Buyers and users of the products described in this brochure must make their own assessment of the suitability and appropriateness of the products for their particular use and the conditions in which they will be used. All queries regarding product suitability, purpose or installation should be directed to the nearest Humes Sales Centre for service and assistance. ©Fletcher Concrete and Infrastructure Limited 2004.

