

**Stem Cap for AVK gate valves  
To AS 2638.1 and AS 2638.2**

**Use:**

For gate valves, non-rising stem, inside screw type

Note: Can not be used for:

- OS&Y gate valves
- Series 57/42 and 57/43
- ISO mounting pad valves

**Materials:**

Stem Cap	Ductile iron, 400-12 to AS 1831
Coating	Electrostatically applied epoxy resin to AS/NZS 4158
Screw	316 SS
Insert	Plastic (Red = CC, White = ACC)

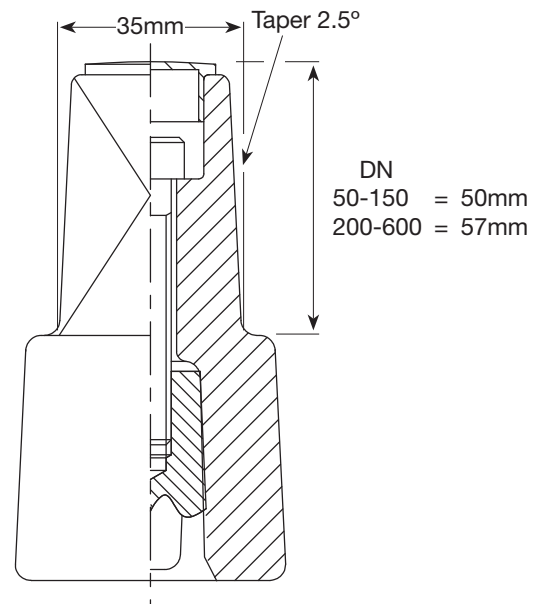
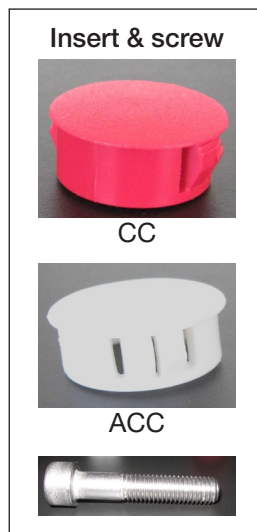

BLUE		PURPLE	TO SUIT SERIES				Weight kilos
Ref. nos. CC	Ref. nos. ACC	Ref. nos. ACC	57/40 PN16	57/90 PN16	57/80 PN25	55 PN16	
57-100-1602	57-100-1612	57-100-1614	50-100	-	50-100	-	0.89
57-090-1602	57-090-1612	57-090-1614	-	50-100	-	-	0.89
57-150-1602	57-150-1612	57-150-1614	150	150-200	150	-	1.06
57-300-1602	57-300-1612		200-300	225-300	200-300	-	1.31
57-400-1602	57-400-1612		375-400	-	-	-	1.84
57-600-1602	57-600-1612		-	-	-	450-600	1.49

AVK Australia's website contains the latest product information and data sheets.

Designs, materials and specifications shown are subject to change without notice due to our continuing program of product development.



AVK Australia Pty Ltd  
559A Grand Junction Road, Wingfield, SA 5013 Australia  
Tel: +61 8 8368 0900  
Fax: +61 8 8368 0970  
E-mail: info@avkvalves.com.au  
www.avkvalves.com.au

3N5716CQ  
March 2011