

SewerBoss™

Wastewater piping solutions



Tough, technically superior and incredibly simple to install – that's SewerBoss™, an extruded, high-technology polypropylene pipe for all sewer system installations and related municipal applications.

While SewerBoss™ can take care of virtually any gravity and low-pressure sewer systems application, its technical superiority means it can be used for a wide range of end use situations, including:

- Gravity and low head sanitary sewers
- Other drainage applications
- Pipeline rehabilitation
- Landfills
- Industrial applications

Features

- UV Resistant
- High strength to weight ratio
- Super smooth inner wall lining
- Range of sizes
- Range of SN rated products
- EPDM rubber rings

Benefits

- Excellent resistance to impact, chemical attack and abrasion
- Easy to handle and transport
- Excellent flow characteristics
- Can be installed in a wide variety of soil types and depths
- Fast and easy to install
- Pipe will not become brittle over time



Structural design

SewerBoss™ pipe is classified as flexible. The structural design procedure for buried flexible pipelines is given in AS/NZS 2566.1 and its supplement. SewerBoss™ SN16 minimum stiffness is 16000 N/m/m.

SewerBoss™ 



Installation

You'll find all installation requirements for buried flexible pipelines are given in AS/NZS 2566.2. For general guidelines the trench should be excavated to a bed width ensuring sufficient clearance (l_c) between the pipe and trench walls. Recommended trench width is detailed in the table below or can be downloaded from the Waters & Farr website at www.watersandfarr.co.nz

Nominal pipe diameter (ID)	Minimum trench width (B)
225mm	0.56m
300mm	0.75m
375mm	0.84m
450mm	1.13m

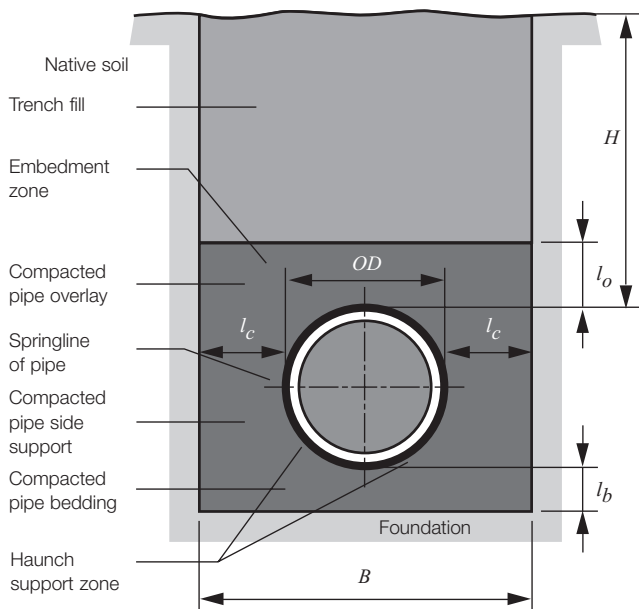

Typical embedment geometry is based on requirements of AS/NZS 2566.1:1998. The recommended minimum thickness of compacted bedding (l_b) and compacted overlay (l_o). Side compaction (l_c) should be in layers of not more than 150mm.

Loading conditions	Min cover (H), m
SewerBoss™ installed under areas not subject to traffic or heaving loading	0.30
SewerBoss™ installed under areas zoned for agriculture use	0.60
SewerBoss™ installed under areas subject to vehicular loading -	
(a) no carriageway:	0.45
(b) sealed carriageways; and	0.60
(c) unsealed carriageways	0.75
SewerBoss™ installed under embankments or subject to construction equipment loads	0.75

Buyers and users of the products described in this brochure must make their own assessment of the suitability and appropriateness of the products for their particular use and the conditions in which they will be used. All queries regarding product suitability, purpose or installation should be directed to the nearest Humes Sales Centre for service and assistance. © Fletcher Concrete and Infrastructure Limited 2008. Printed 02/08.

The manufacturer advises that the **maximum cover (H)** will vary with soil type and traffic loads. **In firm clay soil it is not recommended that SewerBoss™ be installed at a depth greater than 6 metres without approval of the engineer.**

SewerBoss™ product range

SewerBoss™ is available in a range of commonly used internal diameter sizes:

Nominal internal diameter (ID)	Weight (per length)	Colour (stripe/bore)
SN8*		
225mm x 6m	17kg	Blue/Terracotta
300mm x 6m	32kg	Blue/Terracotta
375mm x 6m	50kg	Blue/Terracotta
450mm x 6m	72kg	Blue/Terracotta
SN16		
225mm x 6m	27kg	Red/Terracotta
300mm x 6m	39kg	Red/Terracotta
375mm x 6m	60kg	Red/Terracotta
450mm x 6m	85kg	Red/Terracotta
SN20*		
225mm x 6m	29kg	Purple/Terracotta
300mm x 6m	41kg	Purple/Terracotta
375mm x 6m	63kg	Purple/Terracotta
450mm x 6m	87kg	Purple/Terracotta

*Not available from stock – need to place an order.

The SewerBoss™ system is all about ease of use, which is why you'll only need a combination of the following accessory parts:

- Rubber rings
- Manhole connectors
- Couplers
- Lubricant
- Junctions
- Bends
- Tees
- Reducers

All available from Humes Pipeline Systems.

Quality compliance

SewerBoss™ is manufactured in New Zealand by Waters & Farr and complies to AS/NZS 5065:2005.

