



Concrete Water Tank



Delivery & Installation Guidelines
www.humes.co.nz 0800 502 112

Site Preparation

The site loading of a full 22,500 litre water tank can be in excess of 25 tonnes. This extreme loading requires particular care to distribute the load evenly across the site. Correct site preparation helps to ensure tanks are properly seated for low maintenance. It also facilitates smooth unloading and placement for minimum delivery and installation costs.

1. The site chosen is to be on soil, which is flat, level and firmly compacted across the tank base, 4.1 metres square.
2. The site must be level, firm and free from any obstructions such as large rocks, tree stumps or roots that could cause pressure points and damage the tank.
3. Site foundation must be completely solid to disperse the weight and allow the tank to sit evenly. A tolerance of 15mm is permitted over the entire site. This can be achieved by using a level and straight edge, laser level or similar method.
4. If the site is off-level the tank will not sit straight. If the base is convex, concave or corrugated, this will cause stressing to the base of the tank and may result in tank failure.
5. On the site area spread a 100mm thick base course of GAP 7 metal (1.68 cubic metres) and 50mm of fine sand. The gravel/sand must be evenly distributed over the whole area and carefully levelled off. These base materials must be fully retained within the excavation.
6. If the site is on peat ground a rotten rock layer base 300mm thick is required, then 200mm base course GAP 7, followed by a 100mm layer of fine sand.
7. For sites where the tank is to be partially buried, care must be taken to ensure that the bottom of the site is well drained to prevent flotation of the tank when it is empty.

Other Factors in Selecting an Appropriate Site

1. Ensure that the inlet to your tank is lower than the lowest stretch of spouting. An additional fall may be necessary depending on the distance between the source of water (house roof) and your tank.
2. It is important to pipe the overflow away from the tank base to prevent undermining the site.
3. The size of the base should be at least 4.1 metres square

Concrete Water Tank Range

	Tank	Light Duty Lid (LD)	Heavy Duty Lid (HD)
Capacity (Litres)	22,500		
Item Code	05701	05702	05703
Height (mm)	2750	100	150
Outside Diameter (mm)	3436	3436	3436
Weight (kg)	8239	1994**	3082**

Notes:

- **Standard Tank (body plus LD lid)**
Suitable for above ground installations or partially buried applications
- **Underground Tank (body plus HD lid)**
Suitable to bury, 300mm maximum ground cover above the tank with Class B (light vehicle) traffic loading
- 22,500 litre (5,000 gallon) concrete tanks available in the North Island only
- All tanks will be supplied with 1 x 20mm & 2 x 32mm threaded plugs
- ** Lid weight includes one concrete cover for access

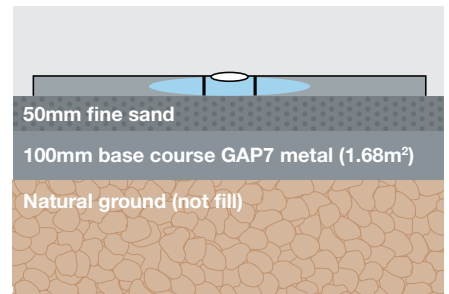

Site to be level in all directions, 4.1m²

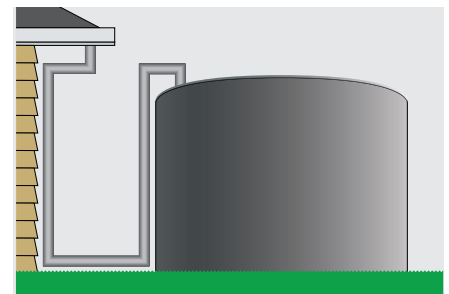

Above ground installation 22,500 litre

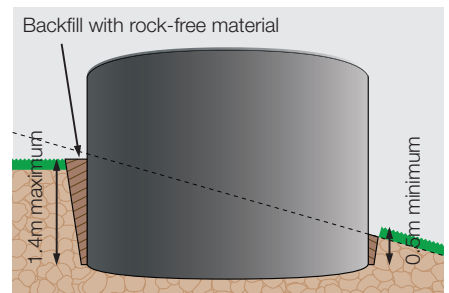

Partially buried installation 22,500 litre

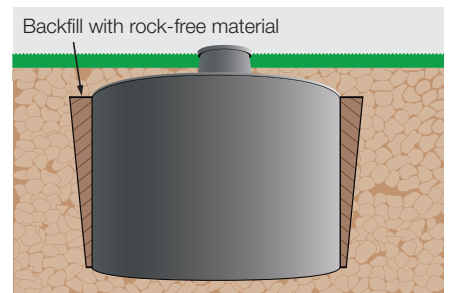

Fully buried installation 22,500 litres

300mm maximum ground cover above the tank with Class B (light vehicle) traffic loading.

Use Holdfast sealant to secure the heavy duty lid before it is completely buried.

Delivery

Tanks are delivered to site and unloaded alongside the truck. If the tank is partially buried or fully buried, the customer will need to hire a crane at their expense to lift the tank into position.

Lifting Method for Water Tanks

For all installations (above ground, partially buried or fully buried) use 4 x lifting anchors on the floor inside of the tank. Figure 1 shows how the water tank is lifted into position using 4 x 5 tonne Reid Swift Lifts and chains.

Light Duty (LD) and Heavy Duty (HD) Lid: 4 x 5 tonne Reid Swift Lifts and chains

Load Securing System for Water Tanks

On the exterior base of the tank (in 4 x positions see Figure 3) there are 4 x pins to secure the tank body to the delivery truck (load securing system). **These pins are to secure the load only and are not to be used to lift the tank body off the truck or into position.** The pins can be patched with cement paste after the tank is placed in its final location and before backfilling with soil.

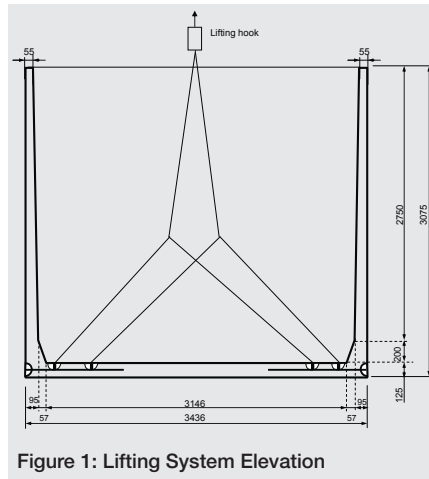

Figure 1: Lifting System Elevation

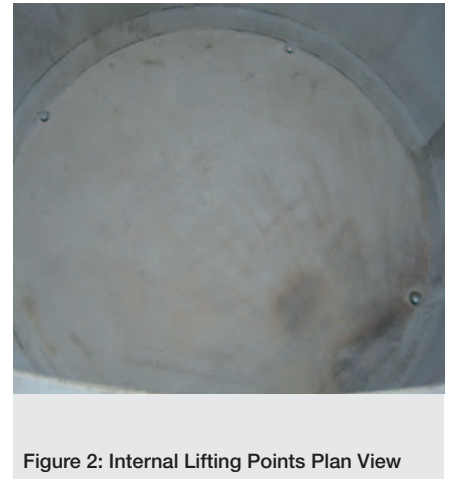

Figure 2: Internal Lifting Points Plan View

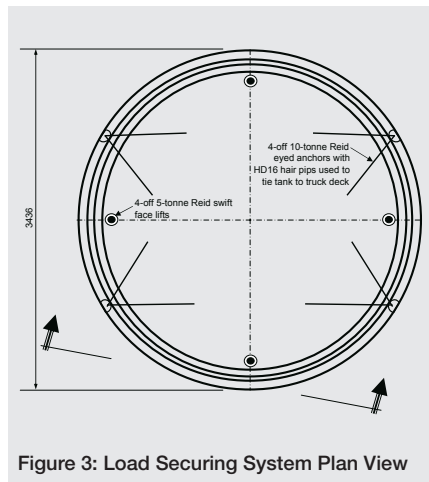

Figure 3: Load Securing System Plan View



Figure 4: Load Securing System Elevation
Pins to secure the load to the truck only.
Not to be used to lift the tank.

Standards and Warranty

All Humes concrete water tanks are manufactured to the NZS 3109:1997 Concrete Construction Standard and are warranted for 10 years (from the date of purchase) to be free of defects caused by poor workmanship or non-compliance to the manufacturing standard. This warranty is valid only to the original purchaser.

Conditions of Warranty:

1. Humes liability is limited to the repair, or if required, replacement of the concrete tank. The decision to repair or replace a concrete tank is at the sole discretion of Humes.
2. Correct preparation of the tank site is the responsibility of the purchaser or their agent (see site preparation details on page 2)
3. Humes accepts no liability for damage caused due to improper handling, site preparation or site situations which are outside our recommendations in the concrete water tank delivery and installation guide.

This warranty does not cover:

- Accidental and negligent damage
- Moving the tank from its original location
- Undermining the ground supporting the tank in any way
- Normal wear and tear
- Failure resulting from natural causes (earthquakes, floods)
- Any repairs to the tank that are carried out by unauthorised people
- Use of the tank for purposes other than for which it was originally intended
- Any damage that occurs after delivery that is the result of incorrect or inadequate site preparation

Water Tank Customer Checklist

- ✓ Is the base prepared ready for the tank installation?
- ✓ Will the tank be installed above ground, partially buried or fully buried?
- ✓ Is the entrance to the property wide enough to deliver the tank? Check access from the property gate along the entire route the delivery truck will need to travel. Minimum width of 4.0m. Suitable site access is the responsibility of the purchaser. Ground conditions and gradient suitable for truck to access site under its own steam.
- ✓ Are there any trees, wires, buildings, gate posts or other obstacles blocking access of the loaded delivery truck? Our truck driver will take every care not to damage property but will not be responsible for damage caused due to restricted access. Total load maximum height of 4.5m.
- ✓ Are there any holes, drains or septic tanks that the truck could fall into when delivering the tank?
- ✓ Is the ground and road access firm enough to take the weight of a loaded truck (up to 40 tonnes)?

The ground where the truck will stand to offload the tank must be firm enough to take the weight of a loaded truck and be clear of any overhead obstructions. Additionally the ground must not slope more than 3 degrees in any direction.

If you have any doubts raise them with us before delivery. If the truck gets stuck on site, the purchaser is responsible to pay towage and extra freight costs.

- ✓ If the tank is to be fully buried has the contractor installed a tank before?
- ✓ If the tank is to be fully buried, has the customer organised a crane on site at their own expense?

For a fully buried application the maximum ground cover above the tank is 300mm with Class B (light vehicle) traffic loading.

Careful access checking can save unnecessary delays in delivery and avoid excess transport costs. Tanks are hoisted or craned into place by an outside contractor at owner's expense.

The Water Tank Customer Checklist and a pre site inspection must be completed before the delivery will be confirmed. Also the base must be prepared and ready prior to delivery.

Humes Sales Centres

Whangarei	09 459 6935	Tauranga	07 578 6114	Kapiti	04 298 2860	Timaru	03 688 2079
Albany	09 415 8150	Rotorua	07 348 4914	Petone	04 568 4219	Alexandra	03 448 8016
Henderson	09 835 1260	New Plymouth	06 757 3457	Thorndon	04 499 7573	Queenstown	03 441 4515
Penrose	09 622 1526	Stratford	06 765 0976	Nelson	03 544 8896	Dunedin	03 455 9981
Takanini	09 269 3693	Hastings	06 870 6011	Christchurch	03 349 4399	Invercargill	03 214 4115
Hamilton	07 849 4861	Palmerston Nth	06 357 7102	Greymouth	03 762 6513		

Humes Pipeline Systems

A FLETCHER CONCRETE & INFRASTRUCTURE LIMITED BUSINESS

0800 502 112