

Concrete Box Culverts modular system solutions

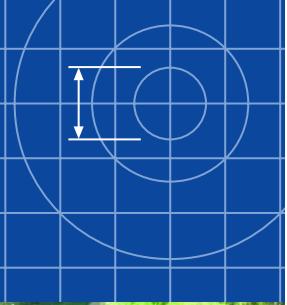

Proven designs for strength and durability

Humes box culverts are readily available throughout New Zealand. This brochure includes information for both designers and users, which is applicable to boxes with spans of 1500mm or more.

Hydraulic characteristics are set out in the Humes Concrete Technical Manual (Pipes), Concrete Pipe Association of Australasia document Hydraulics of Precast Concrete Conduits. This manual should be used when determining required water areas for specific flow situations.

The basic box culvert is available as a full box section. Portal and duct type units can be made from the same moulds.

For shorter spans, refer to the Humes brochure for Concrete Ducting.

Features

- HN:HO-72 loading capability
- Modular design
- Swift lift anchors cast into product
- Product can be customised to suit application
- Wide range of sizes

Benefits

- Suitable for large flows where heavy loads and low headroom exist
- Reduced traffic disruption compared to cast in situ
- Cost effective
- Long design life

Applications

- Waterways
- Cattle underpasses
- Vertical chambers
- Pump stations
- Channels
- Bridging





Applications

Large Flows with Low Headroom

For an equivalent waterway area, box culverts can accommodate significantly larger flows than corrugated pipe alternatives.

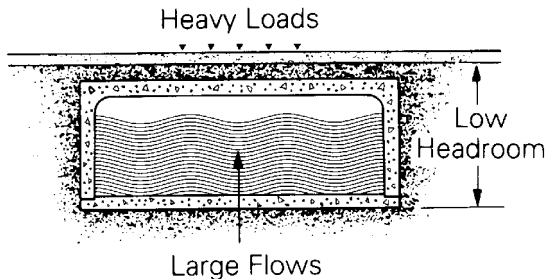

Instant Bridging

Humes box culverts are designed to withstand heavy wheel loads even when there is no fill in place. This provides instant bridging with minimum traffic disruption. (If fill is placed over the culvert, the effect of superimposed load becomes less because the fill will distribute the load over a larger area).

Immediate traffic use is a major benefit compared with any insitu construction and most alternative materials which require the compacted fill in place before loading is applied.

Pedestrian and Stock Crossing, Conveyor Tunnels



Ducting

The use of box culverts as specialised ducting units is especially attractive because of the high cost of other materials. They have been used extensively for electric cable, steam, air, hot water and oil pipe ducting, and as conduits for other materials.

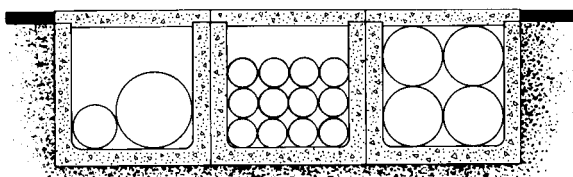

Pump Chambers, Underground Tanks

Full box sections may be installed vertically to form a large range of pump chambers and tanks.

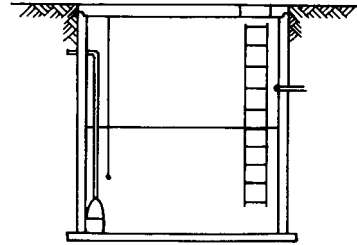

Special Applications

Box culverts may be used as temporary pedestrian protection tunnels on building sites; player protection races at sports grounds; kilns for drying timber; bus shelters.

Culvert types

Humes provide a standard range of full box culvert designs. These designs range from 1500 x 1500 units to 4000 x 4000 units with fill heights between 0 and 2000 Units to other specific designs or standards can be accommodated.

Important: Construction considerations on site may require that heavy equipment travels over box culverts before soil cover is placed. This can result in loading conditions much more severe than those expected in service. Either the design must satisfy construction conditions, or provision must be made to support the units during construction.

Optional Details

- Corner duct holes for site stressing or coupling via tie rods
- Cast in starter bars to tie into insitu wingwalls
- Drill and epoxy starters for headwalls
- Cast in concrete inserts, unistrut and fixing plates to enable welded connection across joints
- Cut outs for pipe access, manhole access, doors etc



Full Box

Full boxes consist of a complete box culvert cell, integrally cast. This type of unit provides maximum onsite construction savings by eliminating the need to pour an insitu base. Moulds can be easily changed to make portals and ducts.



Large Duct and Lid

This type is the invert of the portal and base. It is normally used in sizes of less than 1000 x 1000 mm, but can be specified for large ducts where future access by lid removal is required.

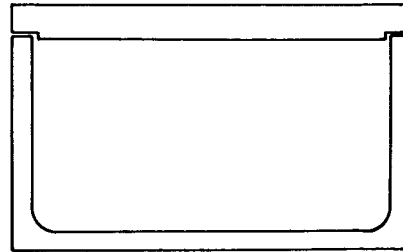

Portal And Base

This structural form is used:

- To reduce transport and handling masses of a full box
- To permit the use of an insitu base, to give continuity over poor foundations
- To provide a shaped invert using insitu concrete to give improved low flow hydraulics
- To provide box culvert heights of less than 1500

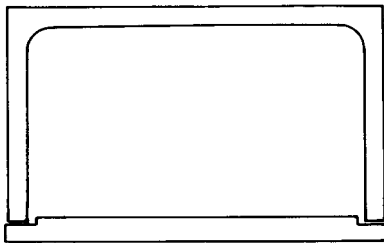

Twin Cell Structure

Providing mass or hydraulics are not constraints, this type offers economy in the cost of precast components and installation. The unit is integrally cast to form two full boxes.

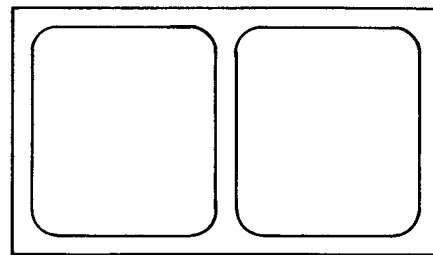

Culvert Segment Configurations

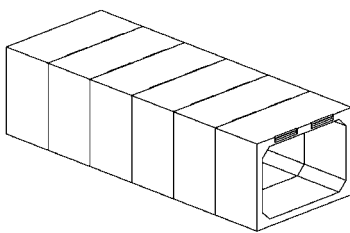

STANDARD BOX CULVERT OR RURAL STOCK UNDERPASS

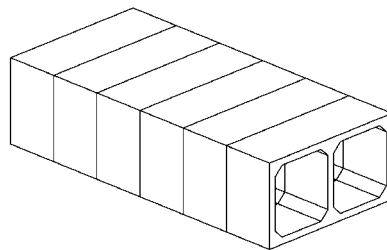

TWIN CELL BOX CULVERTS

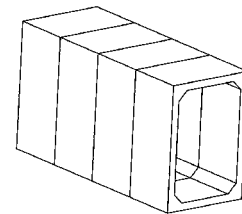

STANDING BOX CULVERTS VARIATION

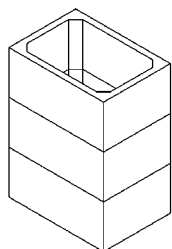

VERTICAL BOX CULVERTS FOR CHAMBER APPLICATIONS

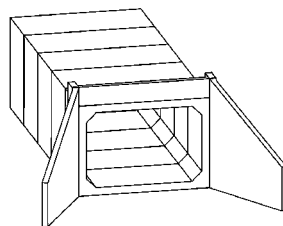

BOX CULVERT WITH OPTIONAL PRECAST WINGWALL AND HEADWALL PANEL

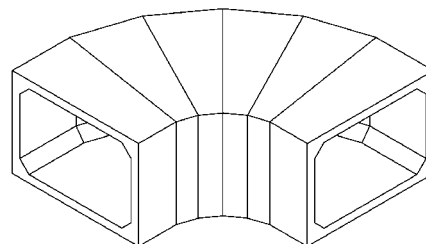

BOX CULVERTS WITH DIRECTIONAL CHANGE



Culvert inlet/outlet arrangements

Kerb and wingwalls can be either precast or insitu concrete.

Options include:

- a) Parallel sided precast wingwalls, made from the box culvert mould, with either stepped or tapered wingwall top surfaces
- b) Wingwalls formed from precast L shape units, tied together with insitu concrete
- c) Wingwalls formed from precast flat slab units, tied together with insitu concrete
- d) For smaller boxes fully precast units
- e) Splay of wingwall can vary according to specific applications

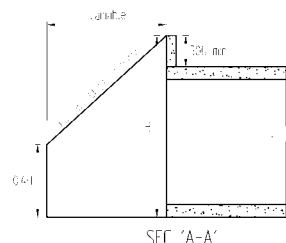
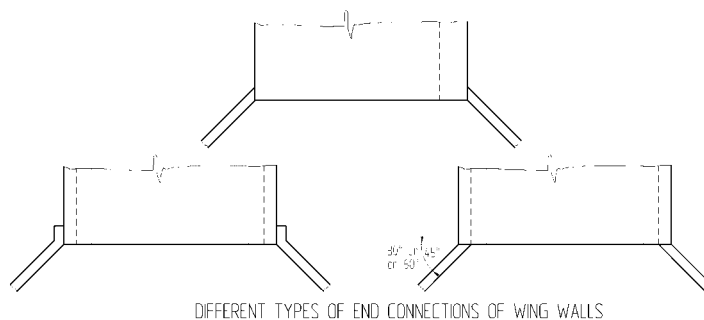
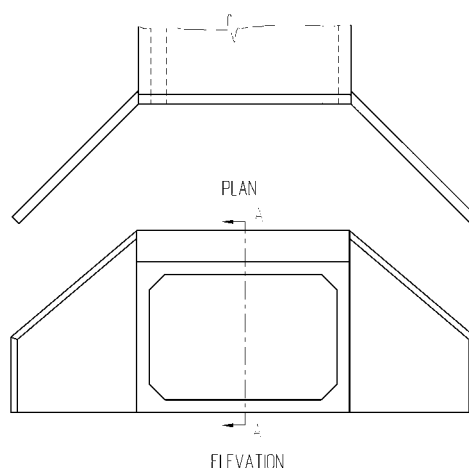
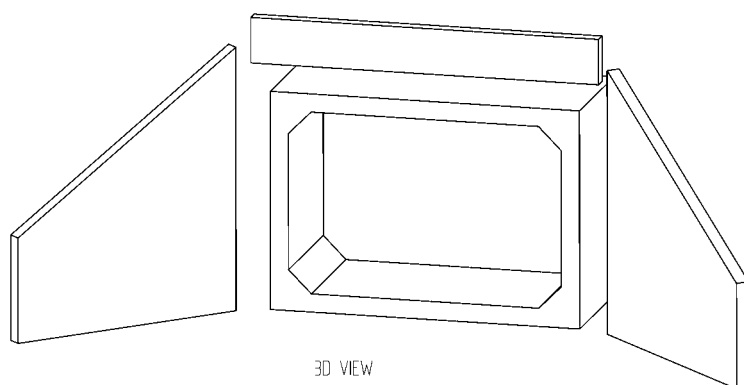

Installation

Handling

It is most important to use the swift lifts provided in each unit to ensure correct handling. In particular, with portal culverts over 1500 span, slings must not be placed around the toes such that large bending moments are induced in the legs. Slings should not be used under the centre of the top slab of the unit. Lateral sliding of box culverts should always be avoided. Culverts should be lifted clear of the ground,

not dragged, so as to avoid any lateral forces at the bottom of the legs.

If portal culverts are to be stored on site, they should be placed on timber bearers and on firm ground. In the case of ducts and full boxes, supports should be placed directly beneath the legs, not towards the centre of the slab.



Laying

Precast bases, ducts and full boxes should be laid on prepared bedding. The bedding material can be compacted sand, cement, stabilising sand or granular material. The compacted thickness of the bedding can range from 100mm for earth foundations to 150mm for rock foundation.

When placing portals on bases or lids on ducts, the surface of the bearing area should be cleaned and covered with mortar or damp proof course so as to ensure uniform bearing. In culverts over 1500 span, any gap between the inside at the leg and recess should be grouted. This will prevent the legs moving due to horizontal loads.

It is acceptable practice to align the ends of portals and bases or ducts and lids so that the joints are not staggered. This ensures that in case of overloading or differential settlement, the slabs and U sections act as units. Loads are thus not transferred partly or imperfectly to the adjacent units.

Backfilling around units should be done in even layers on both side simultaneously. Care must be taken to prevent wedge action against surfaces. This is especially important for large box culverts, long leg lengths, and for slab linked types to ensure the units are not displaced during backfilling.

Heavy earth moving equipment should not run close to or over the culverts without first checking that the units can take the loading that results.

Multicell installation

Where box culverts are laid side by side in multicell installations, they may be placed either touching or with a gap varying from 25mm to a width approximately equal to the box culvert leg thickness.

Actual requirements vary and are generally governed by the size of the culvert, site conditions, and the standard adopted by the particular authority. The gaps should be filled with compacted sand, cement, mortar or grout. Care must be taken with long leg culverts not to use excessive compaction, as forces induced may be in excess of normal design loadings.

A fairing or streamlined nosing is strongly recommended for the upstream and downstream faces of the culvert legs. This requirement is particularly important when a gap is left between adjacent legs usually resulting in a significant total wall thickness.

Jointing

Joints between box culverts used in stormwater drainage conditions do not normally require sealing. Box culverts are usually made with plain ends giving a butt joint. The joint gap is so small that grouting is unnecessary. For special applications such as pedestrian tunnels, ducting systems and sewer lining units can be made with a variety of joints; The common joints are:

Figure 1. Typical joint details

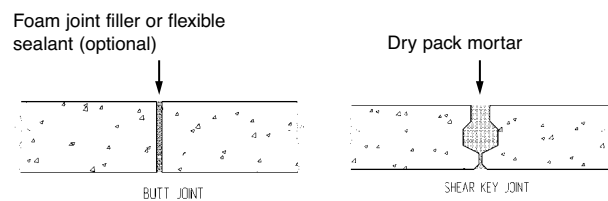

- (a) Deck shear keys (refer fig 1) used in low fill cover situations to transfer wheel loads across the joint
- (b) Plain butt joints (see fig 1) normally associated with higher fill covers and good foundations. Sealants may be incorporated
- (c) Post tensioned or tie rod joints

Units can also be cast with post-tensioning ducts and subsequently tensioned in the longitudinal direction to provide a closed joint and longitudinal integrity. Alternatively, tie rods may be pulled up in the ducts to provide nominal longitudinal integrity.

Note: Where box culverts are laid on a steep grade, suitable jointing is essential to ensure even distribution of load from one culvert to the next. This prevents spalling at the ends due to minor misalignments.

Base Rebates

Portal culvert bases, precast or insitu, must have rebates to prevent the legs being forced inwards by consolidation of the fill material beside the culvert.

The recommended rebate depth for spans over 1500 is 25mm.

In determining width and location of rebates, adequate allowance must be made for dimensional tolerances, particularly span and leg width tolerances.



Dimensions and mass

- Nominal standard sizes are internal dimensions
- Where masses are not shown, size availability is indicated with a “✓”
- Box culverts are generally available in standard lengths of 1550mm. Masses included in Table 2 make this assumption and are based on a nominal concrete density 2440 kg/m³
- In many cases Humes have the facility to manufacture spans and heights greater than 4000mm. Table 3 indicates the extended size range which can be manufactured at some Humes factories. Contact the nearest Humes Sales Centre regarding availability of these larger sizes
- Details of actual box culvert dimensions are available from the nearest Humes Sales Centre
- For box sizes less than 1500 x 1500, refer to Channels and Ducting brochure
- For heights less than 1500 modified box culverts can be manufactured

Range Of Standard Designs

- All 0-600 units incorporate deck shear keys and shear reinforcement in the deck slab as required by NZS3101
- All 600-2000 units are designed for positive projecting embankment conditions

Loading		
Fill Cover (mm)	HN - HO - 72	0.85 HN
0 - 600	✓	✓
600 - 2000	✓	✓

Standard Full Boxes — Size Range

- Slab thickness determined by span and is constant around the box except for 2500 and 4000 span units where walls are 150 and 200 respectively

Height	Mass in tonnes for span of:					
	1500	2000	2500	3000	3500	4000
1500	4.0	4.6	6.3	7.8	8.7	10.3
2000	4.5	5.2	6.9	8.6	9.4	11.0
2500		5.7	7.5	9.4	10.2	11.8
3000			9.3	10.1	11.0	12.6
3500				10.8	11.8	13.4
4000					12.6	14.3
Slab thickness	150	150	200	200	200	225

Non Standard Boxes — Extended Size Range

- Design on a 'one off' basis
- Approx slab thickness = 100mm + span / 30

Height (mm)	Span			
	4500	5000	5500	6000
1500	✓	✓	✓	✓
2000	✓	✓	✓	✓
2500	✓	✓	✓	✓
3000		✓	✓	✓
3500			✓	✓
4000				✓

Design For Durability

- Unless otherwise specified all standard designs are designed for exposure classification B1 (deck and all outside slab steel) and B2 (wall and base inside steel)

Manufacturing standards

Precast manufacture is to NZS 3109:1997 and NZS 3101:1995 with surface finishes to NZS 3114:1987.



Disclaimer: Buyers and users of the products described in this brochure must make their own assessment of the suitability and appropriateness of the products for their particular use and the conditions in which they will be used. All queries regarding product suitability, purpose or installation should be directed to the nearest Humes Sales Centre for service and assistance. © Fletcher Concrete and Infrastructure Limited 2004.

