

Humes Joint Clamps and Sealer

In some regions this jointing system is required to hold risers, lids and bases together to maintain water tightness where manholes could be subject to lateral forces. The system uses galvanised mild steel clamps fitted across the joints after the placement of a sealing compound. Clamps are fitted after the basic construction of the manhole.

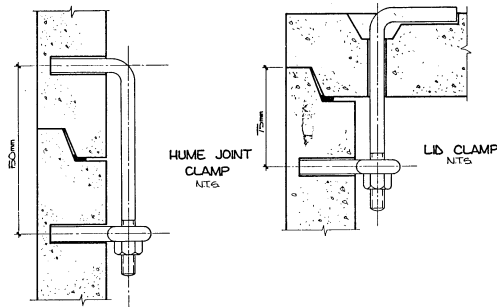

varying dimensions in 750mm lengths. Has shelf life of 6 months when sealed and stored in cool dry conditions. Titanseal is a self-adhering butyl rubber compound extruded into ready to use tape form for non-structural permanent, weathertight sealing of concrete surfaces. Titanseal is easy to handle rolls of tape with virtually unlimited storage life is easily applied, especially in confined spaces as there is no mixing and no agitation of the product. Titanseal can even be made to tack to damp surfaces, but it is prepared to be used on a dry primed surface. Neither special equipment nor skill is required to create a perfect seal. The thickness of the tape compensates for joint tolerances, automatically assuring void free seals of desired depth due to its compressibility and recovery. Titanseal adheres immediately, does not shrink and is unaffected by prolonged climate exposure.

Humbond Epoxy Mortar

Used to join manhole risers and repair, although this can differ from area to area, eg cement mortar used as an alternative.

Humbond Epoxy Mortar is a convenient to use two part silica sand filled adhesive and jointing system developed especially for construction and concrete work.

Humbond will cure under most conditions in thick film to an extremely hard durable surface with negligible exotherm and shrinkage.

Suitable as a patching and forming compound for all concrete products. Used to seal concrete in drainage and construction applications.

Non-standard Manholes

Components of non-standard type and dimensions can be produced for special applications, such as pumping stations wells and shafts. These requirements should be discussed with the nearest Humes sales office.



The Swiftlift Manhole Lifting System

The Swiftlift Manhole Lifting System utilises specially designed spreader beams that are available for sale or hire from your local Humes outlet or branches of Alan H. Reid Engineering Ltd. The spreader beam has three chains which enables it to be used for single, double or three point lifts. When lifting a manhole lid with three lifting points the middle chain should be attached to the lifting point closest to the access hole. This minimises the load being applied to the centre of the beam.

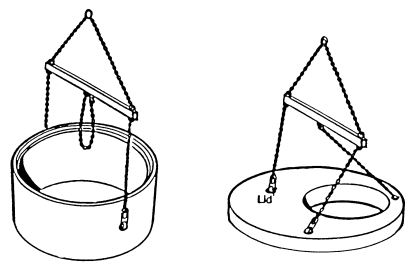

Sealing Strip BM100

Commonly referred to as BM100, a preformed grey sealant based on high molecular weight cross linked butyl rubber. Used to join manhole risers (some areas use alternative sealants eg cement mortar) and is also suitable as a compression seal between lightweight concrete panels. Has a moderate amount of surface tack and deforms readily under moderate loading. Supplied in

Disclaimer: "Buyers and users must make their own assessment of our products under their own conditions for their own use. All queries regarding product suitability or purpose or installation should be directed to the nearest Humes office for advice and assistance". Availability of product may differ slightly from that available in your area. © Copyright Humes Pipeline Systems 2004.



Access for Wastewater or Stormwater Systems

Humes manholes are extensively used throughout New Zealand. Made from strong, dense concrete with ratings typically of 60MPa and above, Humes manholes are capable of withstanding infiltration and attack from corrosive environments. Components such as lids etc. can be designed to HN-HO-72 loadings when required. Design expertise from experienced engineers is available for assistance on standard and non-standard products

Features

- Strength and durability
- Manufactured to New Zealand standards
- Reinforced
- Modular precast system

Benefits

- High resistance to infiltration and leaking
- Able to meet all design requirements
- Reduced construction time with fewer traffic hold-ups, when compared to cast insitu.



Components

A Humes manhole is comprised of many parts. These pages are guide to Humes standard sizes and weights. For any questions on Humes product, please contact your local Humes branch or sales representative.

Note:

All mass data is in kg and assumes a concrete density of 2400, except for riser section which has a concrete density of 2500.

Frames and Covers

Generally these are of cast iron or ductile iron construction conforming to the requirements of the appropriate local authority

Riser Sections

All manhole lengths have flush joint male and female type ends. Provision is made in 1050 diameter risers for the following two options:

- Humes joint clamps
- New tongue and groove flush joint.

The table below shows Humes standard range of riser sizes with the appropriate weights (kg).

Riser sections: Mass Data (kg) — Concrete density 2500

Nominal Diameter	Nominal Riser Length (mm)							
	300	600	900	1200	1500	1800	2100	2440**
mm	300	600	900	1200	1500	1800	2100	2440**
300	23	45	68	91				185
450	44	89	133	177				360
600	68	136	204	272	340	409		553
750	98	195	293	391	489	586		795
900	131	261	392	523	654	784	915	1063
1050	170	341	511	681	851	1022	1192	1385
1350	213	425	638	851	1064	1276	1489	1730
1500	286	572	858	1143	1429	1715	2001	2325
1800	403	805	1208	1611	2013	2416	2819	3275
2050*	513	1027	1540	2053	2567	3080	3593	4175
2300	732	1463	2195	2926	3658	4389	5121	5950
2550	1057	2115	3172	4230	5287	6344	7402	8600
3060								10675

Notes:

- Standard sizes vary from region to region. Check local sales centre for availability.
- Non-standard sizes can be manufactured upon request

Flanged Base Slab: Mass Data (kg) — Concrete density 2400

External Diameter	Internal Diameter	Nominal Base Thickness (mm)			
		100	150	200	250
mm	mm	100	150	200	250
1330	900	333	500		
1495	1050	421	632		
1660	1200	519	779		
1825	1350	628	942		
1975	1500	735	1103		
2310	1800	1006	1509	2012	
2540	2050		1824	2432	
2870	2300		2329	3105	
3180	2550		2859	3812	4765
3710	3060		3892	5189	6486

Flanged Base Slab

Standard manhole flanged bases comprise circular slabs with minimum thicknesses shown in the table below.

The flange projects 150mm from the outer diameter of the manhole riser to provide resistance to floatation.

These reinforced base slabs are factory cast into a manhole riser of any specified standard length.

Provision is made for lifting and placing using swiftlift anchors.

Notes:

- Weights in kg
- Add appropriate riser mass to obtain overall mass of complete base unit.

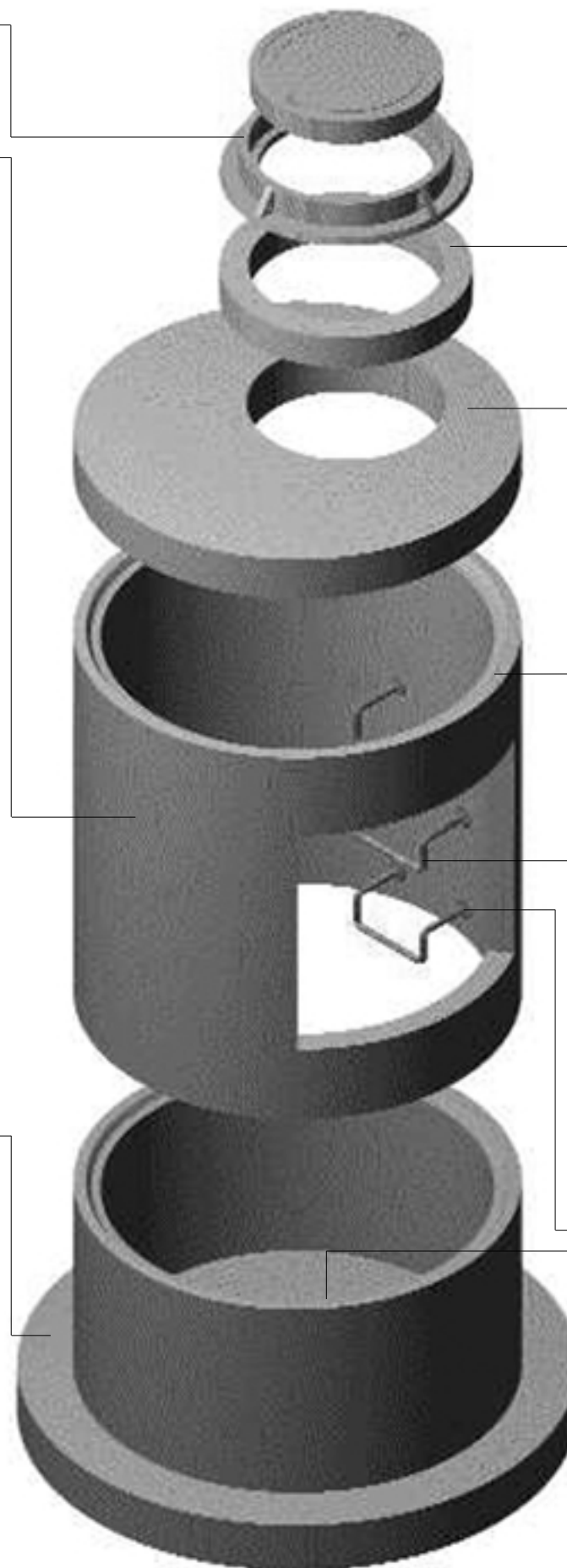

Adjustment Rings

Humes reinforced concrete adjustment rings have an internal diameter of 520mm (outside diameter 675mm) and are available in thicknesses from 30 to 300mm.

The rings are placed over the opening in the manhole lid to make the final height adjustment when placing the frame and cover.

Lids

Reinforced concrete flat lids have diameters which conform to the outer diameters of manhole risers.

The standard opening of 530mm diameter is eccentrically located approximately 150mm radially from the inside of the manhole wall. Swiftlifts are provided.

The minimum thicknesses of standard lids are given in the table below.

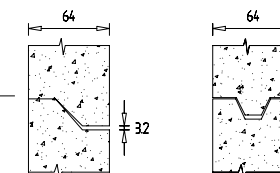

TYPES OF JOINT CROSS SECTIONS

Ladder Rungs

Standard rungs comprise mild steel hot dipped galvanised units of 20mm diameter, 250mm width and 150mm depth; of plain or stepped (safety) type.

Rungs are supplied complete with nuts and steel and rubber washers. See inset diagram for assembly detail.

Provision is made in riser sections for rungs to fitted at 300mm intervals.

Stainless steel and plastic coated rungs are available, as are various types of ladders.

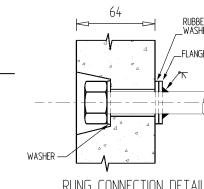

RUNG CONNECTION DETAIL

Unflanged Base

The standard unit comprises a base cast into the bottom section of a manhole riser.

Thicknesses vary according to the manhole diameter, or client's specification.

All bases have reinforcement which is keyed into the riser wall.

Adjustment Rings

Nominal Weight (kg)	11	18	25	35	45	81	112	134
Thickness (mm)	30	50	75	100	150	200	250	300

Lids: Mass Data (kg) — Concrete density 2400

External Diameter	Internal Diameter	Nominal Lid Thickness (mm)					Opening
		75	100	150	200	250	
mm	mm	75	100	150	200	250	
365	300	19	25				None
540	450	41	55				None
700	600	69	92				None
785	675	87	116	174			None
865	750	106	141	220			None
1030	900		200	300			None
1195	1050		216	324	432	541	530mm
1360	1200		296	444	591	739	530mm
1525	1350		385	578	771	964	530mm
1675	1500		476	714	952	1190	530mm
2010	1800			1063	1417	1771	530mm
2240	2050			1339	1786	2232	530mm
2570	2300			1788	2384	2980	530mm
2880	2550			2266	3021	3776	530mm
3410	3060			3208	4278	5347	530mm

Note:

Add appropriate riser mass to obtain overall mass of complete base unit.

Unflanged Base: Mass Data (kg) — Concrete density 2400

Internal Diameter	Nominal Base Thickness (mm)				
	75	100	150	200	250
mm	75	100	150	200	250
300	13	17			
450	29	38			
600	51	68			
750	80	106			
900		153	229		
1050		208	312		
1200		271	407		
1350		344	515		
1500		424	636		
1800		611	916	1221	
2050			1188	1584	
2300			1496	1994	
2550			1839	2451	3064
3060			2647	3530	4412