

**To DIN 3352 part 4
For side tapping
One end external thread, one end internal thread for drilling equipment
and with a tensile resistant socket joint for PE-pipes**

Use:

For water, sewage and neutral liquid applications

Valve designed for use up to 70°C

Where applicable; for AS 4020 compliance, max temp = 40°C

Note: Always observe pipe material recommended operating temperatures
PE-pipe material to max. 20°C

Tests:

Hydraulic test to DIN 3230 part 4:

Seat: PN

Body: 1.5 x PN

Operating torque test

Optional extras:

Handwheel

Extension spindle

Stem cap

Materials:

Body and bonnet Ductile iron, 500-7 to AS 1831

Coating Thermally bonded epoxy resin to DIN 30677 – internally and externally

Stem Stainless steel, DIN X 20 Cr 13

Stem sealing NBR wiper ring, 2 NBR O-rings inside and 2 outside a plastic bearing, EPDM rubber manchette

Wedge Dezincification resistant brass, CZ 132 to AS 2345 vulcanised with EPDM rubber

Thrust collar Dezincification resistant brass, CZ 132 to AS 2345

Bonnet bolts Stainless steel A2, sealed with hot melt

Bonnet gasket EPDM rubber

Socket Fitted with an SBR rubber sealing ring and a tension ring of hard acetal plastic



This information is also available on the AVK Australia website. For further information contact AVK direct.

The designs, materials and specifications shown are subject to change without notice due to our continuing program of product development.



AVK Australia Pty Ltd
559A Grand Junction Road, 5013 Wingfield, S.A.
Tel.: +61 8 8368 0900
Fax: +61 8 8368 0970
e-mail: info@avkvalves.com.au
www.avkvalves.com.au

3N034X6XDQ
November 2008

To DIN 3352 part 4
 For side tapping
 One end external thread, one end internal thread for drilling equipment
 and with a tensile resistant socket joint for PE-pipes

Component list

- | | | |
|-------------------|--------------------------|------------------|
| 1. Stem | 6. Thrust collar | 11. Body |
| 2. NBR wiper ring | 7. EPDM rubber manchette | 12. Sealing ring |
| 3. NBR O-ring | 8. Bonnet bolt | 13. Tension ring |
| 4. Bearing | 9. Bonnet gasket | |
| 5. Bonnet | 10. Wedge | |

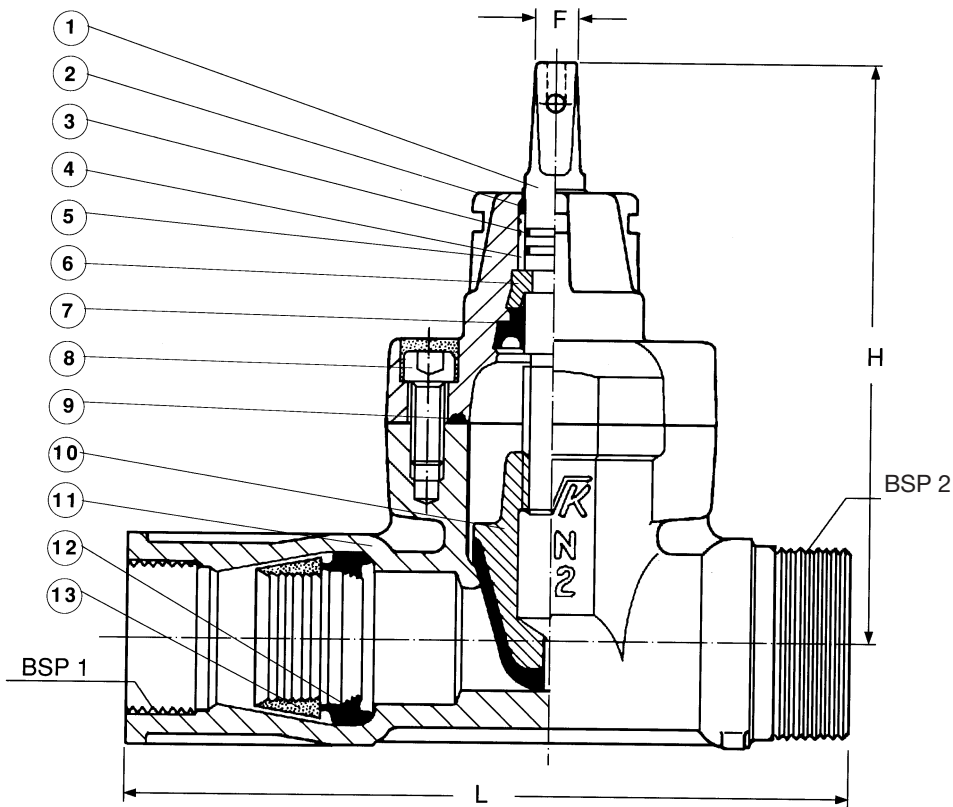

| Ref. nos. clockwise to close | Ref. nos. anti-clockwise to close | DN | BSP 1 mm | BSP 2 mm | PE-pipe D.ex. mm | L mm | H mm | F mm | Weight kilos |
|---------------------------------|--------------------------------------|----|-------------|-------------|------------------------|---------|---------|---------|-----------------|
| 03-032-4X00 | 03-032-4X10 | 25 | 1¼" | 1¼" | 32 | 190 | 180 | 13 | 4.0 |
| 03-040-6X00 | 03-040-6X10 | 32 | 1½" | 1½" | 40 | 221 | 190 | 13 | 5.0 |
| 03-040-4X00 | 03-040-4X10 | 32 | 1½" | 2" | 40 | 221 | 190 | 13 | 5.0 |
| 03-050-4X00 | 03-050-4X10 | 40 | 2" | 2" | 50 | 272 | 203 | 13 | 7.5 |
| 03-063-6X00 | 03-063-6X10 | 50 | 2½" | 2" | 63 | 291 | 213 | 13 | 8.5 |
| 03-063-4X00 | 03-063-4X10 | 50 | 2½" | 2½" | 63 | 291 | 213 | 13 | 8.5 |

X: 0 = Bare shaft
 2 = Stem cap
 3 = Handwheel